



**NEHRU COLLEGE OF ENGINEERING AND RESEARCH CENTRE
(NAAC Accredited)**

(Approved by AICTE, Affiliated to APJ Abdul Kalam Technological University, Kerala)



**DEPARTMENT OF MECHANICAL ENGINEERING
*COURSE MATERIALS***



EST 130 BASICS OF ELECTRONICS ENGINEERING

VISION OF THE INSTITUTION

To mould true citizens who are millennium leaders and catalysts of change through excellence in education.

MISSION OF THE INSTITUTION

NCERC is committed to transform itself into a center of excellence in Learning and Research in Engineering and Frontier Technology and to impart quality education to mould technically competent citizens with moral integrity, social commitment and ethical values.

We intend to facilitate our students to assimilate the latest technological know-how and to imbibe discipline, culture and spiritually, and to mould them in to technological giants, dedicated research scientists and intellectual leaders of the country who can spread the beams of light and happiness among the poor and the underprivileged.

ABOUT DEPARTMENT

- ◆ Established in: 2002
- ◆ Course offered : B.Tech in Mechanical Engineering
- ◆ Approved by AICTE New Delhi and Accredited by NAAC
- ◆ Affiliated to the University of Dr. A P J Abdul Kalam Technological University.

DEPARTMENT VISION

Producing internationally competitive Mechanical Engineers with social responsibility & sustainable employability through viable strategies as well as competent exposure oriented quality education.

DEPARTMENT MISSION

1. Imparting high impact education by providing conducive teaching learning environment.
2. Fostering effective modes of continuous learning process with moral & ethical values.
3. Enhancing leadership qualities with social commitment, professional attitude, unity, team spirit & communication skill.
4. Introducing the present scenario in research & development through collaborative efforts blended with industry & institution.

PROGRAMME EDUCATIONAL OBJECTIVES

PEO1: Graduates shall have strong practical & technical exposures in the field of Mechanical Engineering & will contribute to the society through innovation & enterprise.

PEO2: Graduates will have the demonstrated ability to analyze, formulate & solve design engineering / thermal engineering / materials & manufacturing / design issues & real life problems.

PEO3: Graduates will be capable of pursuing Mechanical Engineering profession with good communication skills, leadership qualities, team spirit & communication skills.

PEO4: Graduates will sustain an appetite for continuous learning by pursuing higher education & research in the allied areas of technology.

PROGRAM OUTCOMES (POS)

Engineering Graduates will be able to:

1. **Engineering knowledge:** Apply the knowledge of mathematics, science, engineering fundamentals, and an engineering specialization to the solution of complex engineering problems.
2. **Problem analysis:** Identify, formulate, review research literature, and analyze complex engineering problems reaching substantiated conclusions using first principles of mathematics, natural sciences, and engineering sciences.
3. **Design/development of solutions:** Design solutions for complex engineering problems and design system components or processes that meet the specified needs with appropriate consideration for the public health and safety, and the cultural, societal, and environmental considerations.
4. **Conduct investigations of complex problems:** Use research-based knowledge and research methods including design of experiments, analysis and interpretation of data, and synthesis of the information to

provide valid conclusions.

5. **Modern tool usage:** Create, select, and apply appropriate techniques, resources, and modern engineering and IT tools including prediction and modeling to complex engineering activities with an understanding of the limitations.
6. **The engineer and society:** Apply reasoning informed by the contextual knowledge to assess societal, health, safety, legal and cultural issues and the consequent responsibilities relevant to the professional engineering practice.
7. **Environment and sustainability:** Understand the impact of the professional engineering solutions in societal and environmental contexts, and demonstrate the knowledge of, and need for sustainable development.
8. **Ethics:** Apply ethical principles and commit to professional ethics and responsibilities and norms of the engineering practice.
9. **Individual and teamwork:** Function effectively as an individual, and as a member or leader in diverse teams, and in multidisciplinary settings.
10. **Communication:** Communicate effectively on complex engineering activities with the engineering community and with society at large, such as, being able to comprehend and write effective reports and design documentation, make effective presentations, and give and receive clear instructions.
11. **Project management and finance:** Demonstrate knowledge and understanding of the engineering and management principles and apply these to one's own work, as a member and leader in a team, to manage projects and in multidisciplinary environments.
12. **Life-long learning:** Recognize the need for, and have the preparation and ability to engage in independent and life-long learning in the broadest context of technological change.

PROGRAM SPECIFIC OUTCOMES (PSO)

PSO1: graduates able to apply principles of engineering, basic sciences & analytics including multi variant calculus & higher order partial differential equations..

PSO2: Graduates able to perform modeling, analyzing, designing & simulating physical systems, components & processes.

PSO3: Graduates able to work professionally on mechanical systems, thermal systems & production systems.

Course Outcomes: After the completion of the course the student will be able to

CO 1	Apply fundamental concepts and circuit laws to solve simple DC electric and magnetic circuits
CO 2	Develop and solve models of magnetic circuits
CO 3	Apply the fundamental laws of electrical engineering to solve simple ac circuits in steady state
CO 4	Describe working of a voltage amplifier
CO 5	Outline the principle of an electronic instrumentation system
CO 6	Explain the principle of radio and cellular communication

Mapping of course outcomes with program outcomes

	PO 1	PO 2	PO 3	PO 4	PO 5	PO 6	PO 7	PO 8	PO 9	PO 10	PO 11	PO 12
CO 1	3	1	-	-	-	-	-	-	-	-	-	2
CO 2	3	1	-	-	-	-	-	-	-	-	-	2
CO 3	3	1	-	-	-	-	-	-	-	-	-	2
CO 4	2	-	-	-	-	-	-	-	-	-	-	-
CO 5	2	-	-	-	-	-	-	-	-	-	-	2
CO 6	2	-	-	-	-	-	-	-	-	-	-	2

Note: H-Highly correlated=3, M-Medium correlated=2, L-Less correlated=1

SYLLABUS

MODULE 4

Introduction to Semiconductor devices: Evolution of electronics – Vacuum tubes to nano electronics. Resistors, Capacitors and Inductors: types, specifications. Standard values, color coding. PN Junction diode: Intrinsic and extrinsic semiconductors, Principle of operation, V-I characteristics, principle of avalanche breakdown and working of Zener diode. Bipolar Junction Transistors: PNP and NPN structures, Principle of operation, relation between current gains in CE, CB and CC, input and output characteristics of common emitter configuration.

MODULE 5

Basic electronic circuits and instrumentation: Rectifiers and power supplies: Block diagram description of a dc power supply, Working of a full wave bridge rectifier, capacitor filter (no analysis), working of simple zener voltage regulator. Amplifiers: Block diagram of Public Address system, Circuit diagram and working of common emitter (RC coupled) amplifier with its frequency response, Concept of voltage divider biasing. Electronic Instrumentation: Block diagram of an electronic instrumentation system, Working of digital multimeter.

MODULE 6

Introduction to Communication Systems: Evolution of communication systems – Telegraphy to 5G. Radio communication: principle of AM & FM, frequency bands used for various communication systems, block diagram of super heterodyne receiver, Principle of antenna – radiation from accelerated charge, working of parabolic reflector. Mobile communication: basic principles of cellular communications, principle and block diagram of GSM.

QUESTION BANK

MODULE 4

Q.NO	Questions	CO	KL
1	Write down the different applications in the field of electronics	CO4	K3
2	Differentiate between active and passive components	CO4	K2
3	Write a short note on active components with examples	CO4	K6
4	Write a short note on passive components with examples	CO4	K6
5	State the ohm's law	CO4	K1
6	What is the colour code for a 4.7k Ω resistor with 5% tolerance value?	CO4	K5
7	What is the nominal resistance of a resistor with colour code orange-white-brown?	CO4	K4
8	What is the colour code for a 560k Ω resistor with 10% tolerance value?	CO4	K5
9	What is the colour code for a 22 Ω resistor with 20% tolerance value?	CO4	K5
10	Describe the different types of fixed resistors	CO4	K1
11	Describe the different types of variable resistors	CO4	K1
12	How capacitors are classified?	CO4	K2
13	Write a short note on inductor and its classifications.	CO4	K3
14	Describe the working of pn junction diode with I-V characteristics.	CO4	K1
15	Describe the working of zener junction diode with I-V characteristics.	CO4	K1
16	Compare avalanche breakdown and zener breakdown	CO4	K1
17	Explain about the operation of NPN transistor.	CO4	K2
18	Explain about the operation of PNP transistor.	CO4	K2
19	Mention the three regions in which a transistor can operate.	CO4	K2
20	Obtain the relationship for the current gain of CE, CB and CC configurations.	CO4	K3
21	Draw and explain the input output characteristics of CE configuration.	CO4	K1

QUESTION BANK

MODULE 5

Q.NO	Questions	CO	KL
1	Draw and explain the working of half wave rectifier	CO5	K2
2	Define Ripple factor	CO5	K1
3	Compare and contrast Half wave rectifier, full wave bridge rectifier and full wave centre tapper rectifier	CO5	K5
4	Draw and explain the working of full wave bridge rectifier	CO5	K1
5	Draw and explain the working of full wave centre tapped rectifier	CO5	K4
6	With suitable diagram explain the working of DC power supply	CO5	K2
7	Give a detailed description about the working of zener voltage regulator.	CO5	K1
8	Explain the working of a Zener voltage Regulator	CO5	K4
9	With the help of a block diagram, explain how a digital multimeter can be used to measure voltage and resistance.	CO5	K5
10	With a neat circuit diagram, explain the working of an RC coupled amplifier.	CO5	K4
11	Draw the frequency response characteristics of an RC coupled amplifier and state the reasons for the reduction of gain at lower and higher frequencies.	CO5	K2
12	Explain the concept of voltage divider biasing	CO5	K1
13	Draw and explain the block diagram of an electronic instrumentation system.	CO5	K1
14	Discuss in detail about public addressing system	CO5	K6
15	Draw and explain the working of a dc power supply.	CO5	K4

QUESTION BANK

MODULE 6

Q.NO	Questions	CO	KL
1	List out the frequency bands used for various communication systems.	CO6	K1
2	Write a short note about the evolution of communication systems	CO6	K3
3	Elaborate in detail about the principle of AM & FM	CO6	K6

4	With neat block diagram, explain super heterodyne receiver.	CO6	K2
5	With neat block diagram explain the stages of GSM	CO6	K1
6	Give a brief description about the principle of antenna.	CO6	K1
7	Explain the principle of GSM.	CO6	K5
8	Differentiate between Amplitude modulation and Frequency modulation.	CO6	K1
9	With neat sketches explain a cellular communication system	CO6	K3
10	Give a detailed description on the evolution of communication systems	CO6	K4
11	Explain the working of parabolic reflector	CO6	K5
12	Discuss the principle in which the radiation from accelerated charge occurs.	CO6	K2

EST130 - BASICS OF ELECTRONICS ENGG

MODULE 4

Evolution of electronics

The word 'electronics' is derived from electron mechanics, which means the study of the behavior of an electron under different conditions of externally applied fields. The Institution of Radio Engineers (IRE) has given a standard definition of electronics as "that field of science and engineering, which deals with electron devices and their utilization."

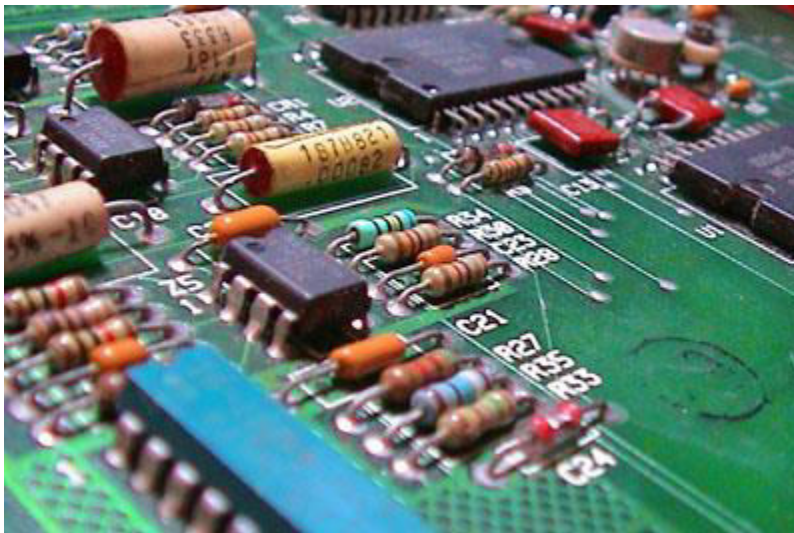

Applications of electronics

Electronics play a major role in almost every sphere of our life. The main applications of electronics are as follows.

Communication and Entertainment In communication,

the main application of electronics was in the field of telegraphy and telephony. This utilizes a pair of wires. However, it is now possible with the help of radio waves to transmit any message from one place to another, thousands of kilometers away, without any wires. With such wireless communication (radio broadcasting), people in any part of the world can know what is happening in other parts. Radio and TV broadcasting provide a means of both communication as well as entertainment. With the help of satellites it has become possible to establish instant communication between places very far apart.

Defense Applications

One of the most important developments during World War II was the RADAR. By using radar it is possible to detect and find the exact location of the enemy aircraft. The antiaircraft guns directed to shoot down the aircraft. The radar and antiaircraft guns can be linked by an automatic control system to make a complete unit.



Guided missiles are completely controlled by electronic circuits. In a war, success or defeat for the nation depends on the reliability of its communication system.

Industrial Applications

Use of automatic control systems in industries is increasing day by day. Electronic circuits are used in industrial applications like control of thickness, quality, weight and moisture content of a material. It is also used in automatic dooropeners, lightning systems, power systems and safety devices.

Medical Sciences

Doctors and scientists are constantly finding new uses for electronic systems in the diagnosis and treatment of various diseases. Some of the instruments which have been in use are: Xrays, for taking pictures of internal bone structures and also treatment of some diseases Electrocardiographs (ECG), to find the condition of the heart of a patient. Short-wave diathermy units, for healing sprains and fractures. Oscillographs for studying muscle action.

Instrumentation

Instrumentation plays a very important role in any industry and research organization, for precise measurement of various quantities. e.g. VTVM, CRO, frequency counters, pH-meters, strain gauges, etc



CRO

Integrated circuit

An integrated circuit or monolithic integrated circuit (also referred to as an IC, a chip, or a microchip) is a set of **electronic circuits** on one small flat piece (or "chip") of **semiconductor** material that is normally **silicon**. The integration of **large numbers** of tiny **MOS transistors** into a small chip results in circuits that are orders of magnitude smaller, faster, and less expensive than those constructed of discrete **electronic components**.

Integrated circuits were made practical by technological advancements in **metal–oxide–silicon (MOS) semiconductor device fabrication**. Since their origins in the 1960s, the size, speed, and capacity of chips have progressed enormously, driven by technical advances that fit more and more MOS transistors on chips of the same size – a modern chip may have many billions of MOS transistors in an area the size of a human fingernail. These advances, roughly following **Moore's law**, make computer chips of today possess millions of times the capacity and thousands of times the speed of the computer chips of the early 1970s.

In the early days of simple integrated circuits, the technology's large scale limited each chip to only a few transistors, and the low degree of integration meant the design process

was relatively simple. **Manufacturing yields** were also quite low by today's standards. As the technology progressed, millions, then billions of transistors could be placed on one chip, and good designs required thorough planning, giving rise to the field of **electronic design automation**, or EDA.

Scale	Components Count	Year
SSI (Small Scale Integration)	< 100	1963
MSI (Medium Scale Integration)	100-1000	1970
LSI (Large Scale Integration)	1000-10000	1975
VLSI (Very Large Scale Integration)	10000 – 10 ⁹	1980
ULSI (Ultra Large Scale Integration)	> 10 ⁶	1990
GSI (Giga Scale Integration)	> 10 ¹⁰	2010

Electronic Components

The main components used in electronics are of two general types: passive and active.

(i) Active components

Components required to be powered in some way to make them work i.e. rely on a source of energy

Examples: Active components include amplifying components such as Vacuum Tubes, Transistors, Integrated Circuits, etc

(ii) Passive components

Doesn't rely on a source of power.

Examples: Passive components include components such as resistors, capacitors, and inductors.

Resistor

Resistors decrease the intensity of the electric current flowing through a circuit. Resistors do not block electricity. Instead, they convert a percentage of the electric current into heat energy, which is transmitted into an area around the device.

Resistance: The ability of the material to oppose current.

The amount of electric current absorbed by a resistor is called "resistance," and is measured in "ohm" units

Ohm: an ohm is defined as the electrical resistance between two points of a conductor when a constant potential difference applied between these points produces a current of one ampere

$$R = V / I$$

A simple analogy with a hydraulic system. Notice that the flow of electricity resembles the flow of water from a point of high potential energy (high voltage) to a point of low potential energy (low voltage). In this simple analogy water is compared to electrical current, the voltage Difference is compared to the head difference between two water reservoirs, and finally the valve resisting the flow of water is compared to the resistor limiting the flow of current.

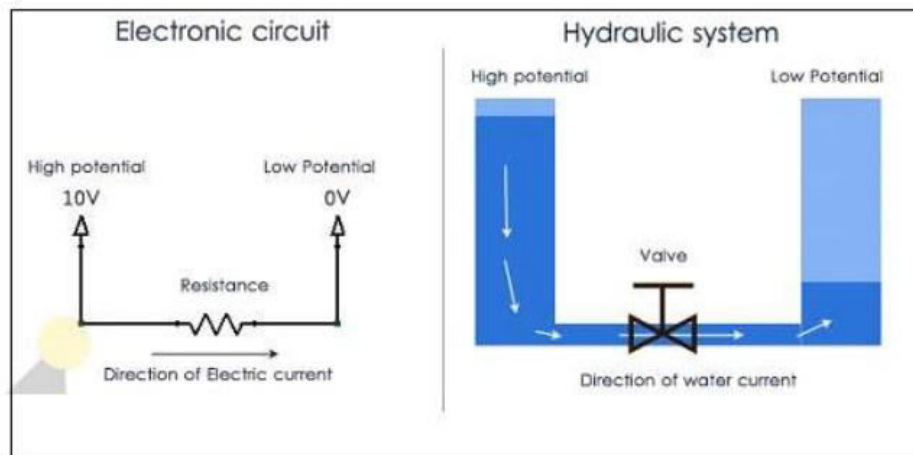

There won't be any flow of current between 2 points if there is no potential difference between them. In other words, for a flow of current to exist, there must be a voltage difference between two points.

The electric current in a conductor will increase with the decrease of the resistance, exactly as the rate of flow of water will increase with the decrease of the resistance of the valve.

A lot more deductions are based on this simple analogy, but those rules are summarized in the most fundamental equations of electronics: Ohm's law.

Ohm's law states that, at constant temperature the current through a conductor between two points is directly proportional to the potential difference or voltage across the two points, and inversely proportional to the resistance between them.

The mathematical equation that describes this relationship is: $R = V / I$

Where

I is the current through the conductor in unit of ampere,

V is the potential difference measured across the conductor in unit of volt,

R is the resistance of the conductor in unit of ohm.

Fixed value Resistors

The value of resistance remains constant and cannot be varied by the user

The major types of fixed resistors are

- (i) Carbon composition resistor
- (ii) wire wound resistor
- (iii) Carbon film resistor
- (iv) Metal film resistor

Choice of resistor for a desired application depends upon the **value of resistance, size, shape, leads, power rating, tolerance, maximum operating voltage ,etc.**

CARBON COMPOSITION RESISTOR

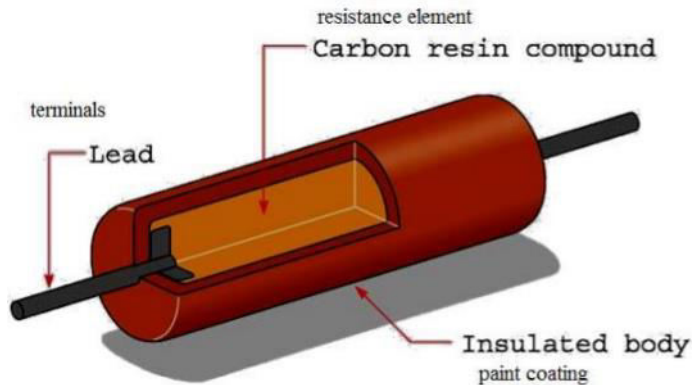

Resistance element: mixture of powdered carbon and powdered insulator.

The resistance element are solidified by a bonding compound and the mixture is extruded into desired shape and size by forcing it through a die.

The process is achieved by sintering in the presence of hydrogen or nitrogen at 1400°C.

Specifications:

Resistance range:	2Ω to 20MΩ
Tolerance:	5% to 10%
Power rating:	0.125W to 2W
Operating Voltage:	125V to 800V
Operating temperature:	-55°C to 150°C
Uses:	General purpose electronic instruments

Wire-wound resistors

Wire-wound resistors are fixed resistors that are made by winding a piece of resistive wire around a cylindrical ceramic core. These are used when a high power rating is required.

The wire is preferred according to its resistivity.

The required resistance can be achieved by varying the thickness and length of the resistive wire during winding process.

The resistive wire has to be tightly wound to the ceramic substrate.

The entire setup is covered by an enamel to prevent it from moisture.



Specifications:

Resistance range:	0.1Ω to 1MΩ
Tolerance:	0.1% to 5%
Power rating:	10W to 75W
Operating Voltage:	<150V
Operating temperature:	55°C to 375°C
Applications:	Low resistance, low noise, higher power handling capacity in small size.

Carbon film resistor

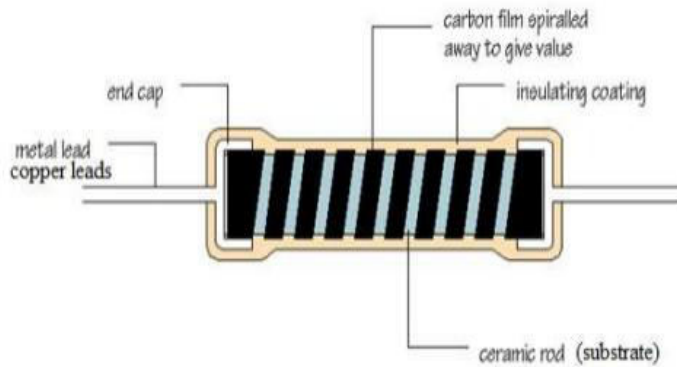

- A thin film of pure carbon is deposited onto a small ceramic rod (substrate) by thermal decomposition at 1000°C.
- The resistive coating is spiralled away in an automatic machine until the resistance between the two ends of the rod is as close as possible to the correct value.
- Metal leads and end caps are added, the resistor is covered with an insulating coating and finally painted with coloured bands to indicate the resistor value.

Specifications:

Resistance range: 1Ω to $10M\Omega$

Tolerance: 1% to 5%

Power rating: 5W

Operating Voltage: 500V

Applications: used in measuring instruments where close tolerances are required.

Carbon film resistors possess better stability than carbon composition resistors, but are of relatively larger size compared to carbon composition resistors. Carbon film resistors cannot withstand electric overloads.

Metal film resistor

Metal film resistors are axial resistors with a thin metal film(Ni) as resistive element. The thin film is deposited on usually a ceramic body(substrate).

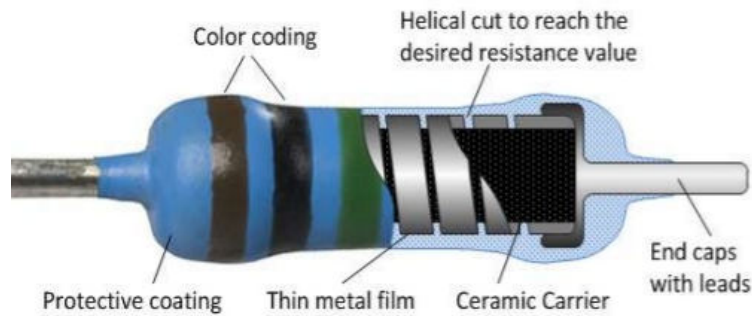

Specifications:

Resistance range:	0.5Ω to 10KΩ
Tolerance:	2% to 3%
Power rating:	5W
Operating Voltage:	300V
Working temperature:	-40 to 150°C

Stable, reliable and capable of handling overload for short time.

Applications: electronic instruments.

Variable resistors

Variable resistors can change their value over a specific range. A potentiometer is a variable resistor with three terminals. A rheostat has only two terminals.

A potentiometer is a three terminal variable resistor used to divide voltage

A rheostat is a variable resistor used to control current

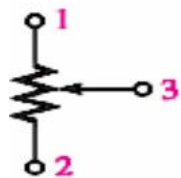
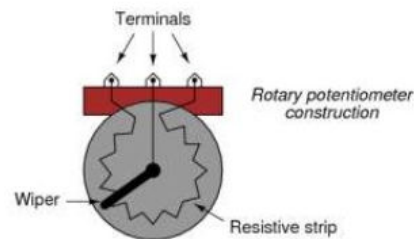

(a) Potentiometer



(b) Rheostat

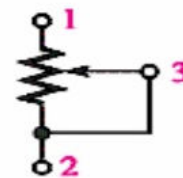

(c) Potentiometer connected

Potentiometers work on the principle that longer lengths of resistance material have greater resistance.

The closer the wiper is to the end terminal it is connected to, the less resistance there is. This is because the current will not have to travel as far. The further away the wiper moves from the terminal it is wired with, the greater the resistance will be.

Potentiometers usually have three connecting points. Two are connected to the ends of the resistance material and the third is connected to the central sliding contact. The slider can either slide in a straight line or around a curve

Types of variable resistors

- (i) Carbon composition potentiometer
- (ii) Wire wound resistor
- (iii) Wire wound solenoid
- (iv) Helical wound POT

Characteristics of Variable resistor:

- (i) resistance law: relation between change in R and movement of wiper
- (ii) Tolerance
- (iii) Insulation resistance(high)
- (iv) Speed of operation
- (v) Life time
- (vi) Ruggedness

CARBON COMPOSITION POTENTIOMETER(POT)

(i) Coated film Carbon composition potentiometer

Resistance element: mixture of carbon, silica and binder

Substrate: ring shaped insulating material

End terminals: brass or phosphor bronze

The resistance element is coated on the ring shaped insulating material.

Applications: Preset POT in T.V brightness and contrast control, radio and measuring instruments.

Specifications:

Range: 100 to $10^7 \Omega$;

power :0.5W to 2.25W;

tolerance: 20% for 1 to $10^6 \Omega$

30% for $> 10^6 \Omega$

(ii) Moulded type Carbon composition potentiometer: the resistance material is moulded into a cavity in a plastic base(substrate).

Wiper(moving contact): carbon brush.

ON& OFF switch can be incorporated in this type of POT

Applications: Computers, Industrial and defence . Also used in HF applications as associated inductive and capacitive effects are low.

Wire wound Solenoid

Resistance element: oxidised form of Nickel,
copper

Former: ceramic or steel in hexagonal or
circular shape

Brush: copper or graphite.

Resistance element is wound on the former.

Range: 500 to 10K Ω .

Current :0.1 to 20A

Helical wound variable resistor

Resistance element is wound on the helical former .

Range: 1 to 125K Ω .

tolerance: 2%

Power rating: 100W to 200W

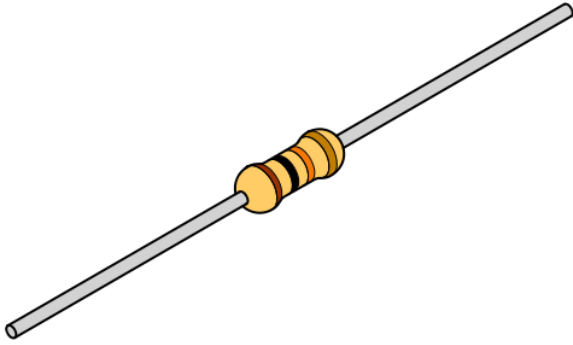

RESISTOR



RESISTOR SYMBOL

A resistor is a passive electronic component that offers a specific amount of electrical resistance to the flow of current when connected in a circuit. Unit of resistance is ohm (Symbol Ω). Ohm is a very small unit. Most practical resistors have resistance in thousands or hundred of thousands of ohm. Therefore resistance is often measured in kilo and megaohms.

Color coding of resistors

Carbon resistors are color coded. Carbon resistors are very small size, it is difficult to write the ohmic values as numbers so color coding is used. Each color has specific numerical values, this help to find the value of the resistor.

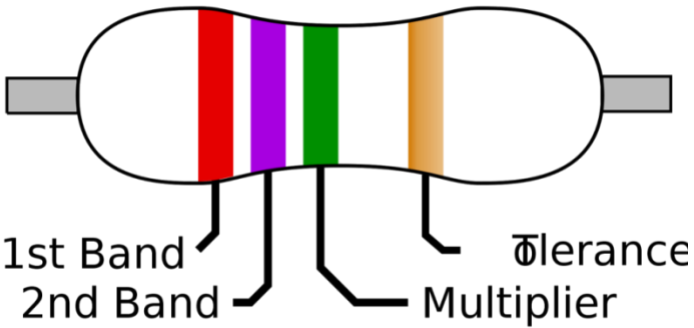

The color bands are read from left to right. The first and second bands represent significant digits respectively of the resistance value. The third band shows the multiplier value. The fourth band gives the tolerance value

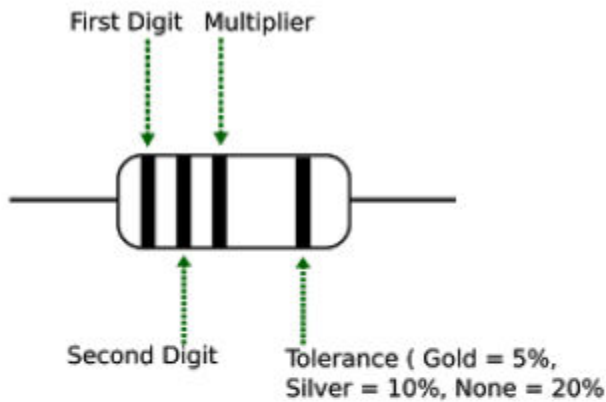

<u>Color</u>	<u>Digit</u>	<u>Multiplier</u>
Black	0	x 1
Brown	1	x 10
Red	2	x 100
Orange	3	x 1K
Yellow	4	x 10K
Green	5	x 100K
Blue	6	x 1M
Violet	7	-
Grey	8	-
White	9	-
Silver	-	x 0.01
Gold	-	x 0.1

CAPACITORS

Capacitor is a physical device which is capable of storing energy by virtue of a voltage existing across it. Capacitor store energy in electrostatic fields. A capacitor consists of two conducting plates separated by an insulating material, The insulating material is known as dielectric. Capacitance is measured by the ability of capacitor to store charge. Capacitance is measured in farads (F). Practical capacitors are measured in microfarads (μF) and picofarads (pF).

$$1 \mu\text{F} = 10^{-6} \text{ F}, 1 \text{ pF} = 10^{-12} \text{ F}, 1 \text{ nF} = 10^{-9} \text{ F}$$

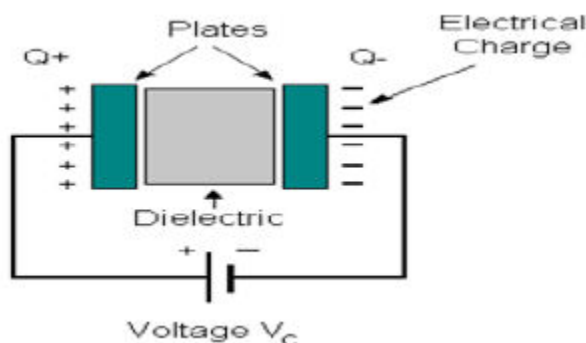

$$Q \propto V; Q = CV$$

Factors Affecting Capacitance

1 Plate Area:

It affects capacitance directly ie, capacitance increases with the increase in plate area (A)

2 Plate Separation:

It affects the capacitance inversely ie, capacitance decreases with the increase in plate separation

3. Type of Dielectric:

It also affects capacitance directly

$$C \propto \frac{\epsilon_r A}{d}$$

$$C = \frac{\epsilon_r \epsilon_0 A}{d}$$

Where ϵ_0 absolute permittivity = $8.854 \times 10^{-14} \text{ F/M}$

ϵ_r Relative permittivity

Classification of capacitors

The capacitors are commonly classified on basis of dielectric material used. The capacitors may be divided in to two classes, namely fixed and variable capacitors. Each type is further sub divided into two types.

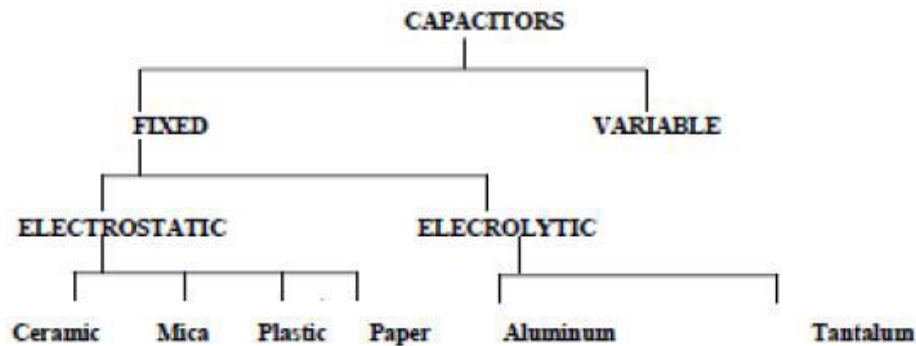

Fixed Capacitors

In fixed capacitors their capacitance value cannot be varied mechanically or by any external means. In fixed capacitors the dielectric is permanently kept in between two fixed plates.

Commonly used fixed capacitors are :

Paper capacitors

Paper capacitors are one of the earliest types of capacitors. They are made by placing paper soaked with mineral oil between two aluminum foils. The entire assembly is rolled up, wire leads are attached to the aluminum foils, and the assembly is enclosed in a cylindrical cardboard case and sealed with wax.



Nominal Capacitance	0.001 μ F to 10 μ F
Working Voltage (at 85°C)	200V to 1600V
Typical Tolerance	10%
Temperature Range	-55°C to 125°C
Temperature Coefficient (PPM/°C)	+/-800
Insulation Resistance (Meg Ohms)	5×10^3
Polarization	Non-Polarized
Dielectric Absorption	2.5%
Dissipation Factor (Operating Losses)	1%
Disadvantage	Size, Hygroscopic and susceptible to moisture
Advantage	Low Cost, Stable, High Voltage Rating
Applications	Motor Capacitors
Cost	Low

Mica & Metalized Mica capacitors

Mica capacitors use mica sheets as a dielectric and are usually constructed as multi-plate capacitors. A variation of mica capacitors use silver inked mica sheets as a dielectric for better immunity to moisture and ionization. Mica capacitors are known for low tolerance (as low as 1%), low operating losses (dissipation factor of 0.001%), high-quality factor, and stability at high frequency

Capacitance value vary from 1pF to 10,000pF

These capacitors are able to withstand very high voltage about 500V due to high dielectric constant.



Plastic film capacitors

Film capacitors include many families of capacitors that use different plastics as a dielectric material. They have nearly replaced the paper capacitors in audio, radio circuits, and circuits operating at low to moderate voltages. Some of the commonly used plastics in film capacitors include Polycarbonate, Polyester (PET), Polypropylene (PP), Polystyrene, Polysulphone, Parylene, Kapton Polyimide, Teflon (PTFE Fluorocarbon), and Metalized Polyester (Metalized Plastic). These capacitors come in a variety of geometries such as oval or round wrap and fill, rectangular epoxy case, round epoxy case, metal hermetically sealed rectangular or round case, and with radial or axial leads.

Nominal Capacitance	1000 pF to 50 μ F
Working Voltage (at 85°C)	50V to 600V
Typical Tolerance	5% to 10%
Temperature Range	-55°C to 125°C
Temperature Coefficient (PPM/°C)	+400
Insulation Resistance (Meg Ohms)	10^5
Polarization	Non-Polarized
Dielectric Absorption	0.3%
Dissipation Factor (Operating Losses)	0.75%
Disadvantage	High Temperature Coefficient, Frequency Dependence
Advantage	Low Cost, Small Size
Applications	DC and low power low frequency AC applications
Cost	Low

Ceramic capacitors

Ceramic capacitors refer to a wide range of capacitors available as disc capacitors, MLC (Multi-Layer Ceramic) capacitors, and SMD capacitors. The composition of these capacitors varies with the manufacturers. Some of the commonly used materials in the construction of ceramic capacitors include strontium titanate, titanium oxide, barium titanate, etc



Nominal Capacitance	100 pF to 1 μF
Working Voltage (at 85°C)	50V to 30,000V
Typical Tolerance	1% to 5%
Temperature Range	-55°C to 125°C
Temperature Coefficient (PPM/°C)	+/-30 to +/-2500
Insulation Resistance (Meg Ohms)	5x10³
Polarization	Non-Polarized
Dielectric Absorption	0.75
Dissipation Factor (Operating Losses)	0.02%
Disadvantage	Cost, Size
Advantage	Low Operating Losses, Stability, Low Tolerance
Applications	High Frequency Applications
Cost	High

Electrolytic capacitors

Electrolytic Capacitors are polarized capacitors that offer high capacitance per unit volume. Since these capacitors are polarized, they must be hooked up in a circuit with the right polarity. They have one terminal as the anode, which is a metal plate coated with metal oxide; a liquid or solid electrolytic serves as the cathode. When DC current flows through the electrolytic capacitor, the metal plate starts oxidizing due to an electrolytic and a thin insulating metal oxide layer is deposited on it which serves as a dielectric. As the metal oxide layer is extremely thin, it offers very high capacitance per unit volume. Generally, these capacitors are designed to maximize the surface area of the anode.

When connecting these capacitors in reverse polarity, the electrolyte starts emitting gas which expands in the sealed body of the capacitor and may lead to an explosion. These capacitors have significant leakage current, which makes them unsuitable for many applications.

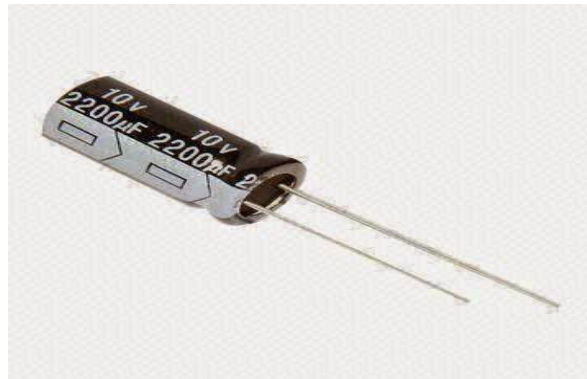
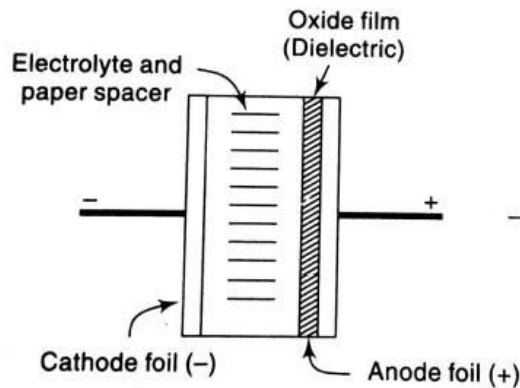

Nominal Capacitance	0.1 μF to 47,000 μF
Working Voltage (at 85°C)	3V to 600V
Typical Tolerance	20%
Temperature Range	-40°C to 85°C
Temperature Coefficient (PPM/°C)	+2500
Insulation Resistance (Meg Ohms)	100
Polarization	Polarized
Dielectric Absorption	8
Dissipation Factor (Operating Losses)	10%
Disadvantage	Polarized, High Operating Losses, Leakage Current
Advantage	High Volumetric Capacitance
Applications	Power Supply Filters, Audio Circuits
Cost	High

Variable capacitors

The capacitance of the variable capacitors can be varied by changing distance between the conducting plates or by changing the mutual surface area between overlapping plates.

Air Variable (Air-Gap Trimmer) – These variable capacitors have a rotatable set of plates called rotor and a fixed set of plates called stator. The capacitance is varied by rotating a control shaft which varies the distance or surface area between the plates. These capacitors can have a capacitance of a few Picofarad to 1000 Picofarad and voltage rating up to thousands of volts. These non-polarized capacitors were commonly used in RF and audio circuits. Varactor diodes have almost replaced these capacitors.

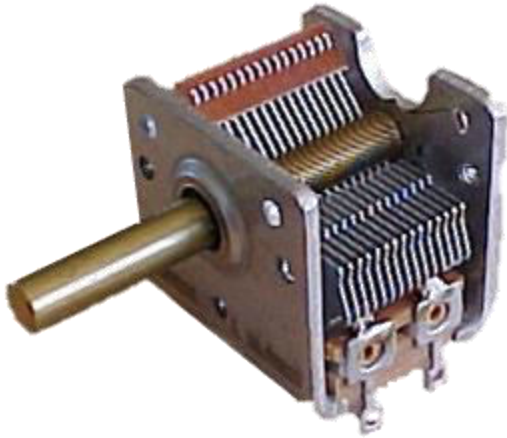

Colour coding of capacitor

Band	Digit	Digit	Multiplier	Tolerance	Tolerance
Colour	A	B	D	(T) > 10pf	(T) < 10pf
Black	0	0	x1	± 20%	± 2.0pF
Brown	1	1	x10	± 1%	± 0.1pF
Red	2	2	x100	± 2%	± 0.25pF
Orange	3	3	x1,000	± 3%	
Yellow	4	4	x10,000	± 4%	
Green	5	5	x100,000	± 5%	± 0.5pF
Blue	6	6	x1,000,000		
Violet	7	7			
Grey	8	8	x0.01	+80%,-20%	
White	9	9	x0.1	± 10%	± 1.0pF
Gold			x0.1	± 5%	
Silver			x0.01	± 10%	

Inductor

This is the third classification of Passive components. It stores the energy in the form of magnetic field and delivers it as and when required

Whenever current pass through a conductor ,lines of magnetic flux are generated around it. This magnetic flux opposes any change in current due to the induced emf . This opposition to the change in current is known as inductance and the component producing inductance is known as inductor.

Unit of inductance is Henry (H). The induced emf is actually given by

$$e = -L \frac{d_i}{d_t}$$

Where e = induced emf in volts in any instant

L= Inductance in Henry

$\frac{d_i}{d_t}$ = rate of change of current

The negative sign indicates that the induced emf opposes the cause for the change in current

An inductor is actually a coil of copper wire wound around a core made up of a ferromagnetic material. The inductance L of the coil is given by

$$L = \frac{\mu_0 \mu_r A N^2}{l}$$

Where μ_0 = Permiability of free space = $4\pi \times 10^{-7} \text{H/m} = 1.257 \times 10^{-6} \text{H/m}$

μ_r = relative permiability of the core

N= number of turns of the coil

L= length of the core

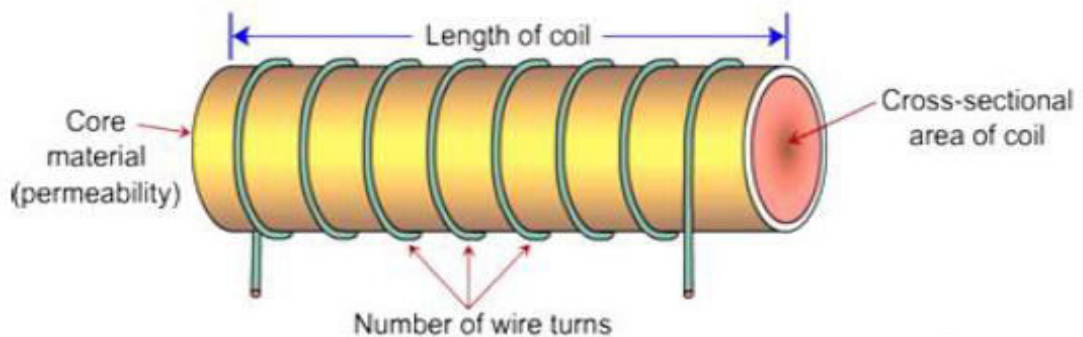

Hence the value of the inductor depends on the following factors

- i) Number of turns
- ii) Permeability of the material
- iii) Size of the core

Inductors can be further divided into two categories

- i) Fixed inductors
- ii) Variable inductors

Inductor Types

There are many different types of inductor, each with their own properties - understanding the properties of the different types is essential for selecting the right type for a circuit.

Inductors perform a number of different styles of function within a circuit. Some types can be used for filtering and removing spikes on power lines, others are used within high performance filters. Others may be used within oscillators, and there are many other areas where inductors can be used.

As a result of this, there are many different types of inductor that can be obtained. Size, frequency, current, value, and many other factors means that there is a whole host of different types and forms of inductor.



INDUCTOR SYMBOL

Different inductor core types

Like other types of component such as the capacitor, there are very many different types of inductor. However it can be a little more difficult to exactly define the different types of inductor because the variety of inductor applications is so wide.

Although it is possible to define an inductor by its core material, this is not the only way in which they can be categorised. However for the basic definitions, this approach is used.

- **Air cored inductor:** This type of inductor is normally used for RF applications where the level of inductance required is smaller. The fact that no core is used has several advantages: there is no loss within the core as air is lossless, and this results in a high level of Q, assuming the inductor or coil resistance is low. Against this the number of turns on the coil is larger to gain the same level of inductance and this may result in a physical increase in size.
- **Iron cored inductor:** Iron cores are normally used for high power and high inductance types of inductor. Some audio coils or chokes may use iron laminate. They are generally not widely used.
- **Ferrite cored inductor :** Ferrite is one of the most widely used cores for a variety of types of inductor. Ferrite is a metal oxide ceramic based around a mixture of Ferric Oxide Fe_2O_3 and either manganese-zinc or nickel-zinc oxides which are extruded or pressed into the required shape.



Inductors on a toroidal ferrite former

- **Iron power inductor:** Another core that can be used in a variety of types of inductor is iron oxide. Like ferrite, this provides a considerable increase in the permeability, thereby enabling much higher inductance coils or inductors to be manufactured in a small space

Different mechanical inductor types and applications

Inductors may also be categorised in terms of their mechanical construction. There are a number of different standard types by which inductors may be categorised:

- **Bobbin based inductor:** This type of inductor is wound on a cylindrical bobbin. They may be designed for printed circuit board mounting, even surface mount if they may be much larger and mounted via some other mechanical means. Some older versions of these inductors may even be in a similar format to normal leaded resistors.

- **Toroidal inductor:** This form of inductor is wound on a toroid - a circular former. Ferrite is often used as the former as this increases the permeability of the core. The advantage of a toroid is that the toroid enables the magnetic flux to travel in a circle around the toroid and as a result the flux leakage is very low. The disadvantage with a toroidal inductor is that it requires a special winding machine is required to perform the manufacture as the wire has to be passed through the toroid for each turn required.



- **Multilayer ceramic inductor:** This type of inductor is widely used for surface mount technology. The inductor is manufactured within a ferrite or more commonly a magnetic ceramic material. The coil is contained within the body of the ceramic and is presented to the external circuit on end caps in the same way as chip capacitors, etc.
- **Film inductor:** This form of inductor uses a film of conductor on a base material. The film is then etched or shaped to give the required conductor profile.

PN JUNCTION DIODE

A PN-junction diode is formed when a p-type semiconductor is fused to an n-type semiconductor creating a potential barrier voltage across the diode junction

However, if we were to make electrical connections at the ends of both the N-type and the P-type materials and then connect them to a battery source, an additional energy source now exists to overcome the potential barrier.

The effect of adding this additional energy source results in the free electrons being able to cross the depletion region from one side to the other. The behaviour of the PN junction with regards to the potential barrier's width produces an asymmetrical conducting two terminal device, better known as the **PN Junction Diode**.

A *PN Junction Diode* is one of the simplest semiconductor devices around, and which has the characteristic of passing current in only one direction only. However, unlike a resistor, a diode does not behave linearly with respect to the applied voltage as the diode has an exponential current-voltage (I-V) relationship and therefore we can not describe its operation by simply using an equation such as Ohm's law.

If a suitable positive voltage (forward bias) is applied between the two ends of the PN junction, it can supply free electrons and holes with the extra energy they require to cross the junction as the width of the depletion layer around the PN junction is decreased.

By applying a negative voltage (reverse bias) results in the free charges being pulled away from the junction resulting in the depletion layer width being increased. This has the effect of increasing or decreasing the effective resistance of the junction itself allowing or blocking current flow through the diode.

Then the depletion layer widens with an increase in the application of a reverse voltage and narrows with an increase in the application of a forward voltage. This is due to the differences in the electrical properties on the two sides of the PN junction resulting in physical changes taking place. One of the results produces rectification as seen in the PN junction diodes static I-V (current-voltage) characteristics. Rectification is shown by an asymmetrical current flow when the polarity of bias voltage is altered as shown below.

Junction Diode Symbol and Static I-V Characteristics

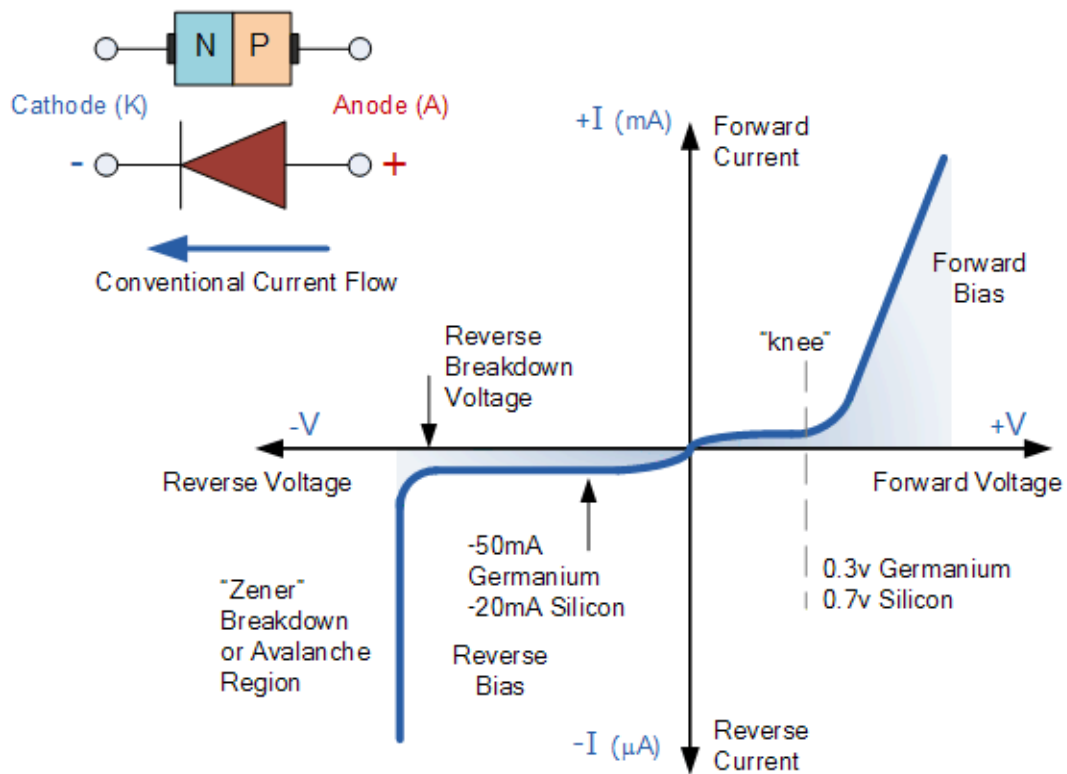

But before we can use the PN junction as a practical device or as a rectifying device we need to firstly **bias** the junction, ie connect a voltage potential across it. On the voltage axis above, “Reverse Bias” refers to an external voltage potential which increases the

potential barrier. An external voltage which decreases the potential barrier is said to act in the “Forward Bias” direction.

There are two operating regions and three possible “biasing” conditions for the standard **Junction Diode** and these are:

- 1. Zero Bias – No external voltage potential is applied to the PN junction diode.
- 2. Reverse Bias – The voltage potential is connected negative, (-ve) to the P-type material and positive, (+ve) to the N-type material across the diode which has the effect of **Increasing** the PN junction diode’s width.
- 3. Forward Bias – The voltage potential is connected positive, (+ve) to the P-type material and negative, (-ve) to the N-type material across the diode which has the effect of **Decreasing** the PN junction diodes width.

Zero Biased PN Junction Diode

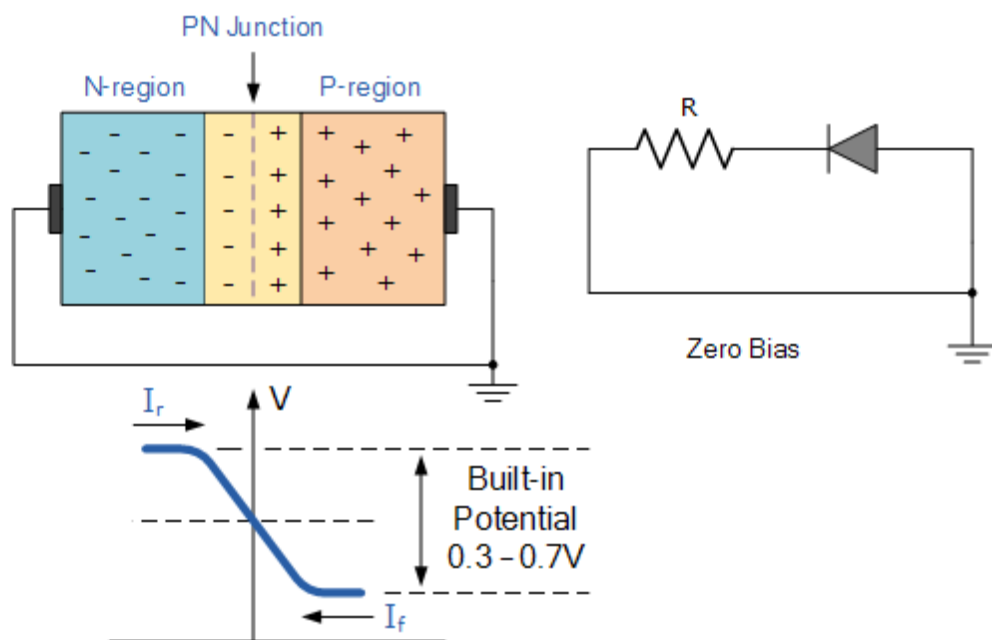

Increase in the Depletion Layer due to Reverse Bias

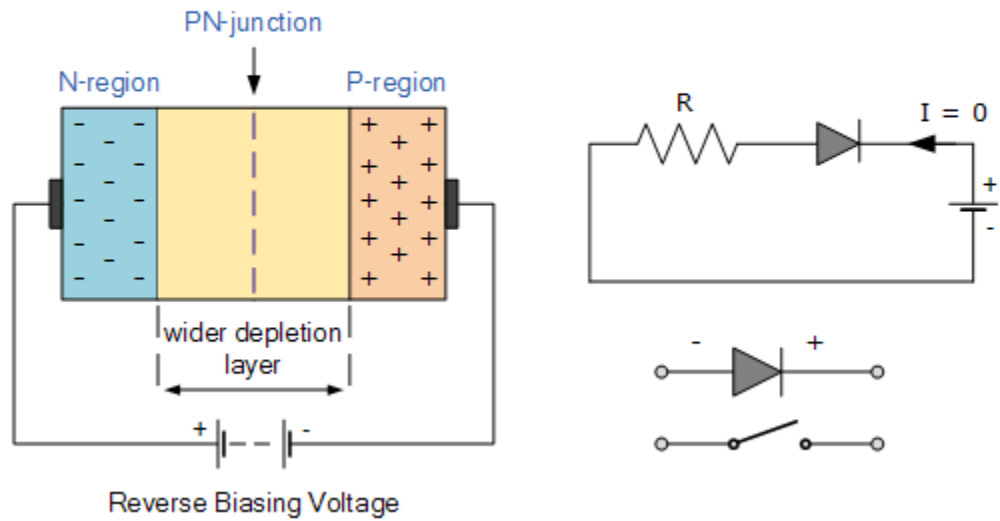

Reduction in the Depletion Layer due to Forward Bias

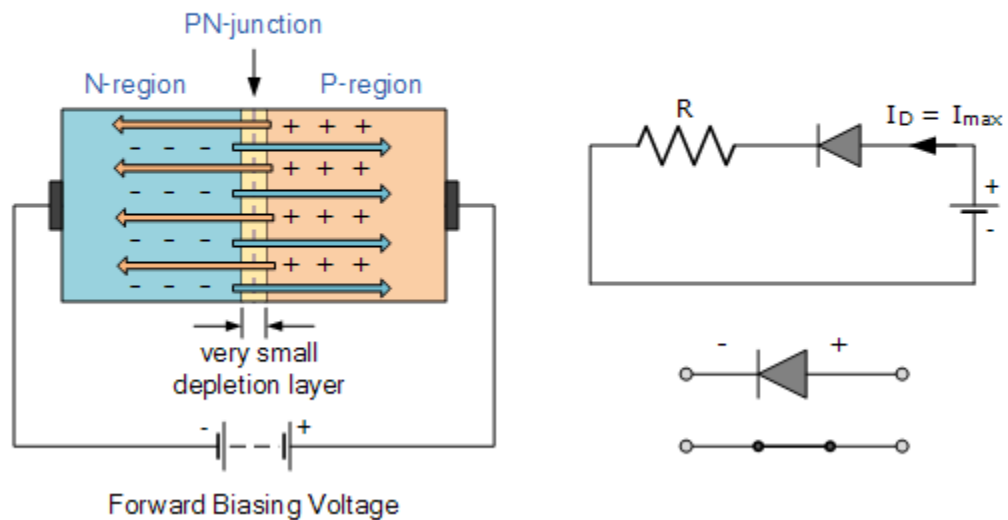

Junction Diode Summary

The PN junction region of a **Junction Diode** has the following important characteristics:

- Semiconductors contain two types of mobile charge carriers, “Holes” and “Electrons”.
- The holes are positively charged while the electrons negatively charged.

- A semiconductor may be doped with donor impurities such as Antimony (N-type doping), so that it contains mobile charges which are primarily electrons.
- A semiconductor may be doped with acceptor impurities such as Boron (P-type doping), so that it contains mobile charges which are mainly holes.
- The junction region itself has no charge carriers and is known as the depletion region.
- The junction (depletion) region has a physical thickness that varies with the applied voltage.
- When a diode is **Zero Biased** no external energy source is applied and a natural **Potential Barrier** is developed across a depletion layer which is approximately 0.5 to 0.7v for silicon diodes and approximately 0.3 of a volt for germanium diodes.
- When a junction diode is **Forward Biased** the thickness of the depletion region reduces and the diode acts like a short circuit allowing full current to flow.
- When a junction diode is **Reverse Biased** the thickness of the depletion region increases and the diode acts like an open circuit blocking any current flow, (only a very small leakage current).

ZENER DIODE

- A **Zener diode** is a type of diode that allows current to flow in the conventional manner - from its anode to its cathode i.e. when the anode is positive with respect to the cathode. When the voltage across the terminals is reversed and the potential reaches the *Zener voltage* (or "knee"), the junction will breakdown and current will flow in the reverse direction - a desired characteristic. This effect is known as the *Zener effect*, after *Clarence Zener*, who first described the phenomenon. Zener diodes are manufactured with a great variety of Zener voltages (V_z) and some are even variable.
- Zener diodes have a highly doped **p-n junction**. A similar **break down** is observed in general purpose diodes (which might be quite high), but the voltage and sharpness of the knee is not clearly defined as in Zener diodes. Normal diodes are not designed to operate in the breakdown region and it can cause permanent failure of the device. Zener diodes are manufactured to operate reliably and quite precisely in this region, recovering fully from the junction breakdown and not being harmed in proper use.

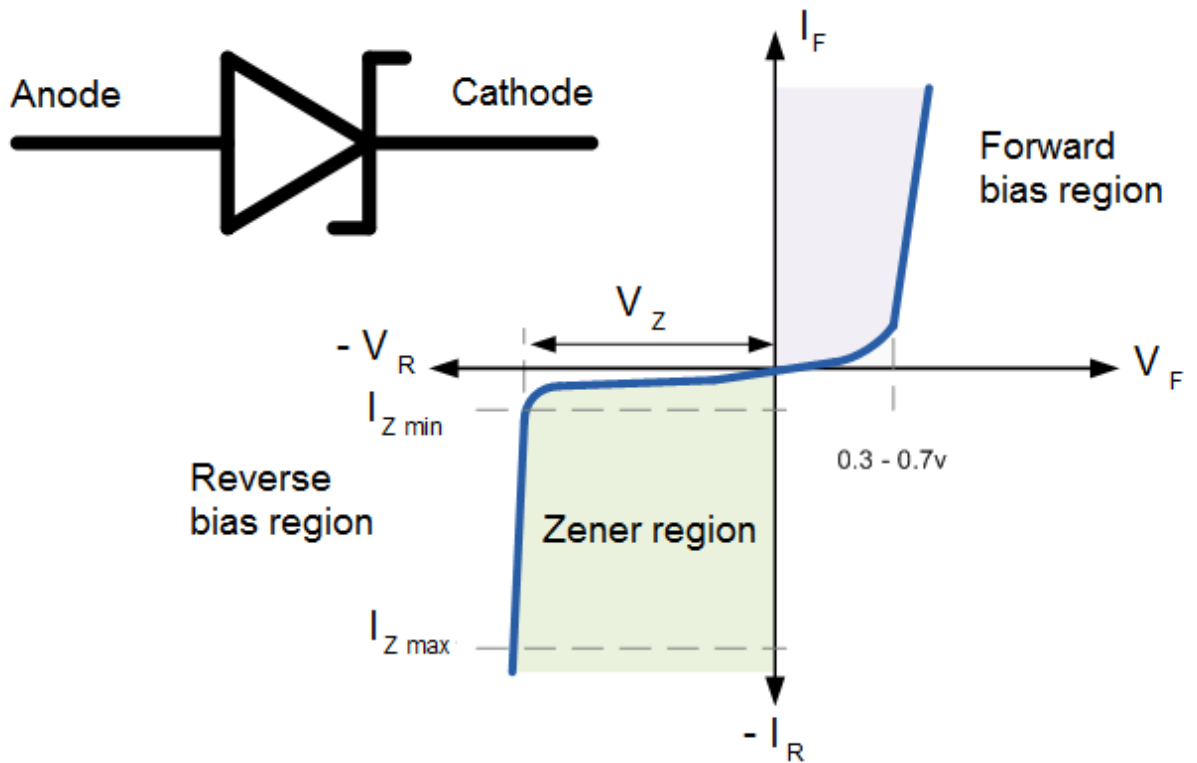

AVALANCHE BREAK DOWN AND ZENER BREAK DOWN

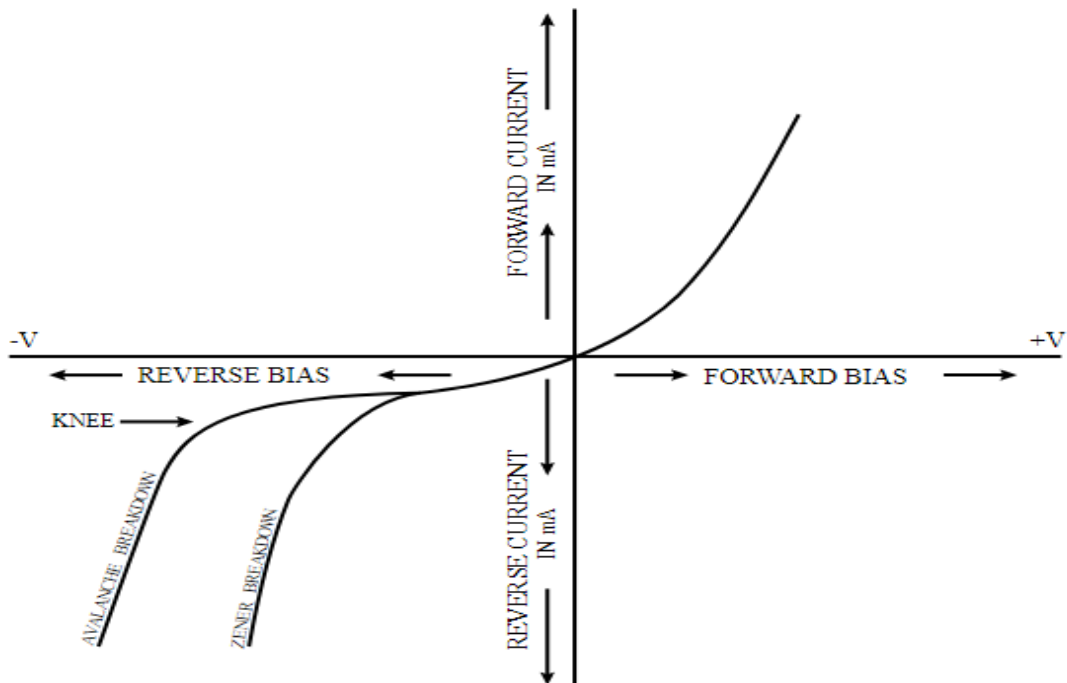

Avalanche breakdown is a phenomenon that can occur in both **insulating** and **semiconducting** materials. It is a form of **electric current** multiplication that can allow very large currents within materials which are otherwise good insulators. It is a type of **electron avalanche**. The avalanche process occurs when carriers in the transition region are accelerated by the electric field to energies sufficient to create mobile or free electron-hole pairs via collisions with bound electrons.

Materials conduct electricity if they contain mobile charge carriers. There are two types of charge carriers in a semiconductor: **free electrons** (mobile electrons) and **electron holes** (mobile holes which are missing electrons from the normally occupied electron states). A normally bound electron (e.g., in a bond) in a reverse-biased **diode** may break loose due to a thermal fluctuation or excitation, creating a mobile electron-hole pair. If there is a voltage gradient (electric field) in the semiconductor, the electron will move towards the positive voltage while the hole will move towards the negative voltage. Usually, the electron and hole will simply move to opposite ends of the crystal and enter the appropriate electrodes. When the electric field is strong enough, the mobile electron or hole may be accelerated to high enough speeds to knock other bound electrons free, creating more free charge carriers, increasing the current and leading to further "knocking out" processes and creating an avalanche. In this way, large portions of a normally insulating crystal can begin to conduct.

The large voltage drop and possibly large current during breakdown necessarily leads to the generation of heat. Therefore, a diode placed into a reverse blocking power application will usually be destroyed by breakdown if the external circuit allows a large current. In principle, avalanche breakdown only involves the passage of electrons and need not damage to the crystal. **Avalanche diodes** (commonly encountered as high voltage **Zener diodes**) are constructed to break down at a uniform voltage and to avoid **current crowding** during breakdown. These diodes can indefinitely sustain a moderate level of current during breakdown.

The voltage at which the breakdown occurs is called the **breakdown voltage**. There is a **hysteresis** effect; once avalanche breakdown has occurred, the material will continue to conduct even if the voltage across it drops below the breakdown voltage. This is different from a **Zener diode**, which will stop conducting once the reverse voltage drops below the breakdown voltage.

DIFFERENCE BETWEEN ZENER AND AVALANCHE BREAKDOWN

Zener Breakdown

1. This occurs at junctions which being heavily doped have narrow depletion layers
2. This breakdown voltage sets a very strong electric field across this narrow layer.
3. Here electric field is very strong to rupture the covalent bonds thereby generating electron-hole pairs. So even a small increase in reverse voltage is capable of producing Large number of current carriers.
4. Zener diode exhibits negative temp: coefficient. i.e. breakdown voltage decreases as temperature increases.

Avalanche breakdown

1. This occurs at junctions which being lightly doped have wide depletion layers.
2. Here electric field is not strong enough to produce Zener breakdown.
3. Her minority carriers collide with semi conductor atoms in the depletion region, which breaks the covalent bonds and electron-hole pairs are generated. Newly generated charge carriers are accelerated by the electric field which results in more collision and generates avalanche of charge carriers. This results in avalanche breakdown.
4. Avalanche diodes exhibits positive temp: coefficient. i.e breakdown voltage increases with increase in temperature.

BIPOLAR JUNCTION TRANSISTOR

A Bipolar Junction Transistor (BJT) is a three terminal semiconductor device in which the operation depends on the interaction of both majority and minority carriers and hence the name Bipolar. The BJT is analogous to a vacuum triode and is comparatively smaller in size. It is used in amplifier and oscillator circuits, and as a switch in digital circuits. It has wide applications in computers, satellites and other modern communication systems.

CONSTRUCTION

The BJT consists of a silicon (or germanium) crystal in which a thin layer of N-type Silicon is sandwiched between two layers of P-type silicon. This transistor is referred to as PNP. Alternatively, in a NPN transistor, a layer of P-type material is sandwiched between two layers of N-type material. The two types of the BJT are represented in Fig. 6.1.

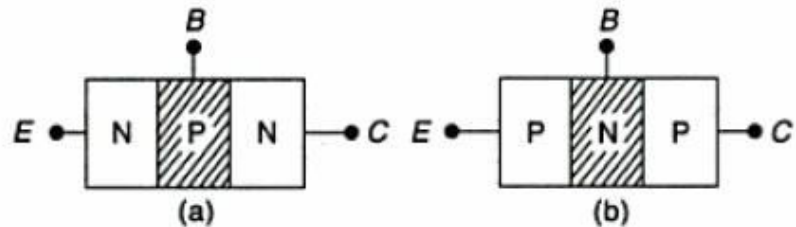

Fig. 6.1 Transistor (a) NPN and (b) PNP

The symbolic representation of the two types of the BJT is shown in Fig. 6.2. The three portions of the transistor are Emitter, Base and Collector, shown as *E*, *B* and *C*, respectively. The arrow on the emitter specifies the direction of current flow when the *EB* junction is forward biased.

Emitter is heavily doped so that it can inject a large number of charge carriers into the base. Base is lightly doped and very thin. It passes most of the injected charge carriers from the emitter into the collector. Collector is moderately doped.

TRANSISTOR BIASING

As shown in Fig. 6.3, usually the emitter-base junction is forward biased and collector-base junction is reverse biased. Due to the forward bias on the emitter-base

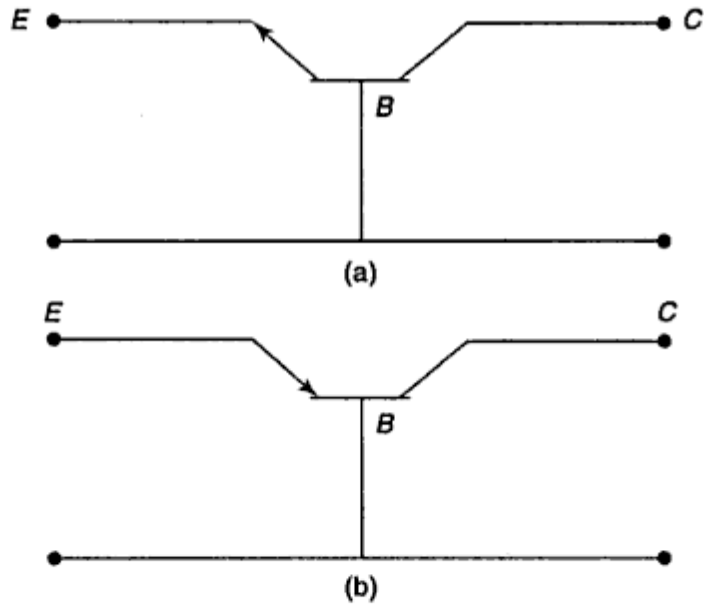

Fig. 6.2 Circuit symbol. (a) NPN transistor and (b) PNP transistor

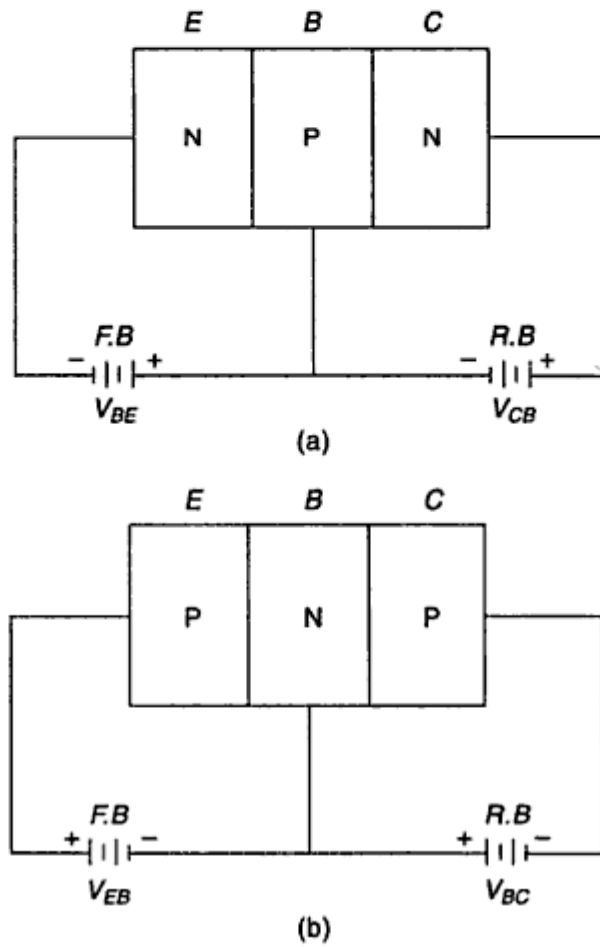

Fig. 6.3 Transistor biasing (a) NPN transistor and (b) PNP transistor

OPERATION OF NPN TRANSISTOR

As shown in Fig. 6.4, the forward bias applied to the emitter base junction of an NPN transistor causes a lot of electrons from the emitter region to crossover to the base region. As the base is lightly doped with P-type impurity, the number of holes in the base region is very small and hence the number of electrons that combine with holes in the P-type base region is also very small. Hence a few electrons combine with holes to constitute a base current I_B . The remaining electrons (more than 95%) crossover into the collector region to constitute a collector current I_C . Thus the base and collector current summed up gives the emitter current, i.e. $I_E = -(I_C + I_B)$.

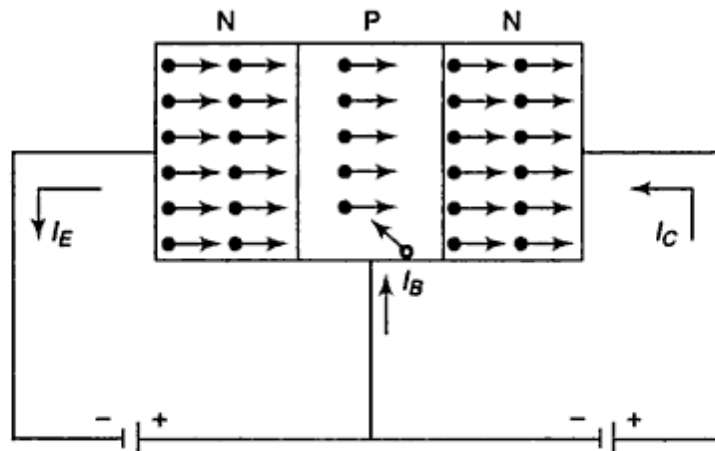

Fig. 6.4 Current in NPN transistor

In the external circuit of the NPN bipolar junction transistor, the magnitudes of the emitter current I_E , the base current I_B and the collector current I_C are related by $I_E = I_C + I_B$.

OPERATION OF PNP TRANSISTOR

As shown in Fig. 6.5, the forward bias applied to the emitter-base junction of a PNP transistor causes a lot of holes from the emitter region to crossover to the base region as the base is lightly doped with N-type impurity. The number of electrons in the base region is very small and hence the number of holes combined with

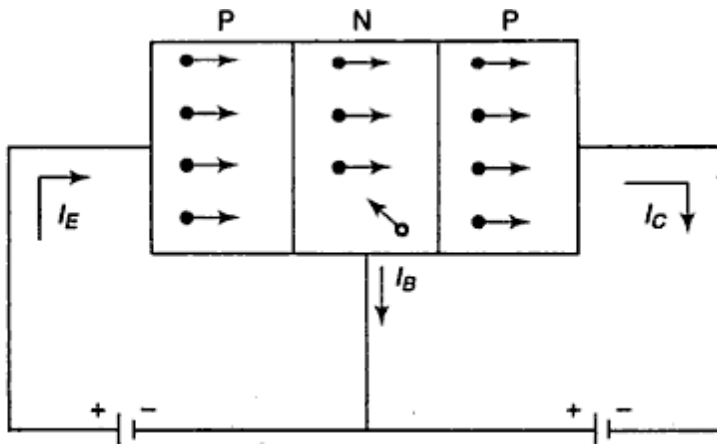

Fig. 6.5 Current in PNP transistor

electrons in the N-type base region is also very small. Hence a few holes combined with electrons to constitute a base current I_B . The remaining holes (more than 95%) crossover into the collector region to constitute a collector current I_C . Thus the collector and base current when summed up gives the emitter current, i.e. $I_E = -(I_C + I_B)$.

In the external circuit of the PNP bipolar junction transistor, the magnitudes of the emitter current I_E , the base current I_B and the collector current I_C are related by

$$I_E = I_C + I_B \quad (6.1)$$

This equation gives the fundamental relationship between the currents in a bipolar transistor circuit. Also, this fundamental equation shows that there are current amplification factors α and β in common base transistor configuration and common emitter transistor configuration respectively for the static (d.c.) currents, and for small changes in the currents.

Types of Transistor Configurations

The three different kinds of transistor configurations are

- Common base transistor configuration
- Common emitter transistor configuration
- Common collector transistor configuration

Common Base Transistor Configuration (CB)

The common base transistor configuration gives a low i/p while giving a high o/p impedance. When the voltage of the CB transistor is high, the gain of the current and overall gain of the power is also low compared to the other transistor configurations. The

main feature of the B transistor is that the i/p and o/p of the transistor are in phase. The following diagram shows the configuration of CB transistor. In this circuit, the base terminal is mutual to both i/p & o/p circuits.

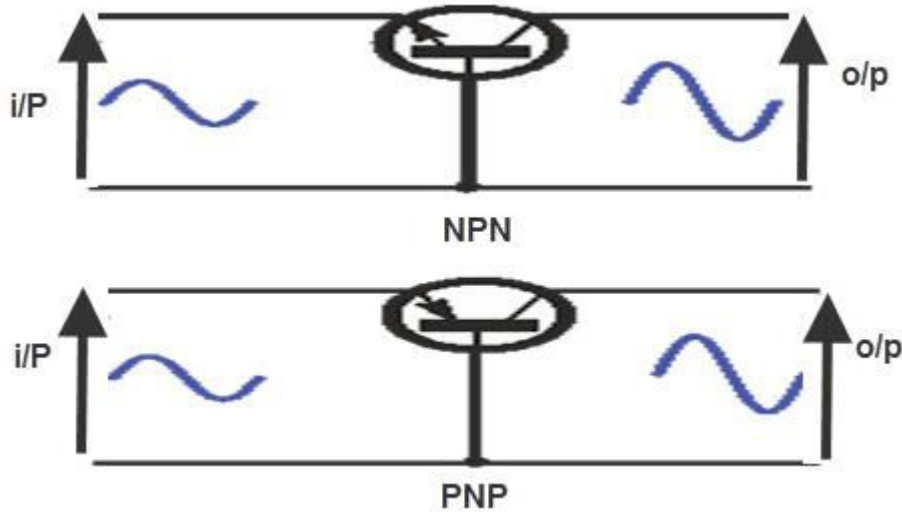

The current gain of the CB circuit is calculated in a method related to that of the CE concept and it is denoted with alpha (α). It is the relationship between collector current and emitter current. The current gain is calculated by using the following formula.

Alpha is the relationship of collector current (output current) to emitter current (input current). Alpha is calculated using the formula:

$$\alpha = (\Delta I_C) / \Delta I_E$$

Common Collector Transistor Configuration (CC)

The common collector transistor configuration is also known as the emitter follower because the emitter voltage of this transistor follows the base terminal of the transistor. Offering a high i/p impedance & a low o/p impedance are commonly used as a buffer. The voltage gain of this transistor is unity, the current gain is high and the o/p signals are in phase. The following diagram shows the configuration of CC transistor. The collector terminal is mutual to both i/p and o/p circuits.

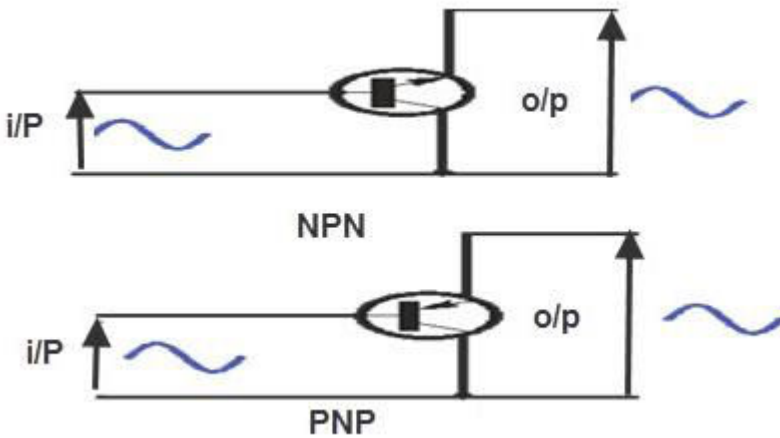

The current gain of the CC circuit is denoted with (γ) and it is calculated by using the following formula.

$$\gamma = \frac{I_E}{I_B}$$

Common Emitter Transistor Configuration (CE)

The common emitter transistor configuration is most widely used configuration. The circuit of CE transistor gives a medium i/p and o/p impedance levels. The gain of the both voltage and current can be defined as a medium, but the o/p is opposite to the i/p that is 180° change in the phase. This gives a good performance and it is frequently thought of as the most commonly used configurations. The following diagram shows the configuration of CE transistor. In this kind of circuit, the emitter terminal is mutual to both i/p & o/p.

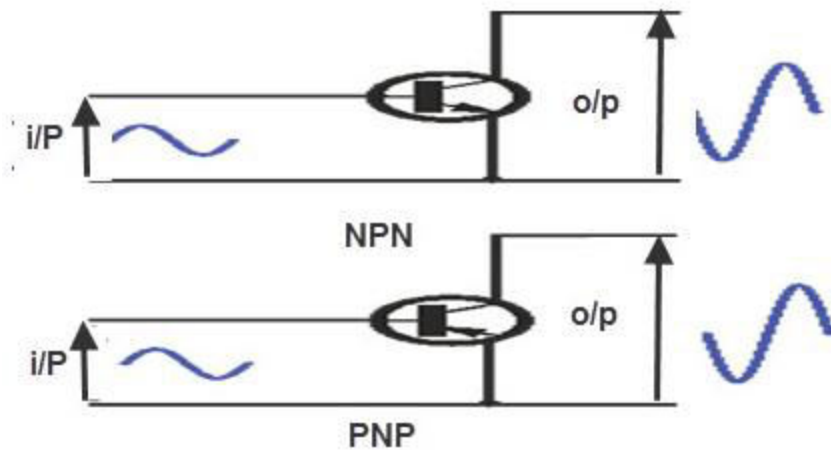

The current gain of the common emitter (CE) circuit is denoted with beta (β). It is the relationship between collector current and base current. The following formula is used to calculate the beta (β). Delta is used to specify a small change

$$\beta = \frac{I_C}{I_B}$$

Relationship between α_{dc} and β_{dc}

For an NPN transistor

$$I_E = I_B + I_C$$

Dividing each term by I_C we get

$$\frac{I_E}{I_C} = \frac{I_B}{I_C} + \frac{I_C}{I_C}$$

or

$$\frac{I_E}{I_C} = \frac{I_B}{I_C} + 1$$

$$\frac{1}{\alpha_{dc}} = \frac{1}{\beta_{dc}} + 1$$

$$\frac{1}{\alpha_{dc}} = \frac{1 + \beta_{dc}}{\beta_{dc}}$$

$$\alpha_{dc} = \frac{\beta_{dc}}{1 + \beta_{dc}}$$

Similarly, we can prove that

$$\beta_{dc} = \frac{\alpha_{dc}}{1 - \alpha_{dc}}$$

$$\alpha_{dc} = \frac{\beta_{dc}}{\beta_{dc} + 1}$$

© www.petervis.com

$$\beta_{dc} = \frac{\alpha_{dc}}{1 - \alpha_{dc}}$$

© www.petervis.com

Similarly we can prove,

$$\gamma = \beta + 1$$

INPUT AND OUTPUT CHARACTERISTICS OF COMMON EMITTER CONFIGURATION

Transistor Characteristics are the plots which represent the relationships between the current and the voltages of a transistor in a particular configuration. By considering the transistor configuration circuits to be analogous to two-port networks, they can be analyzed using the characteristic-curves which can be of the following types

1. **Input Characteristics:** These describe the changes in input current with the variation in the values of input voltage keeping the output voltage constant.
2. **Output Characteristics:** This is a plot of output current versus output voltage with constant input current.
3. **Current Transfer Characteristics:** This characteristic curve shows the variation of output current in accordance with the input current, keeping output voltage constant.

Common Emitter (CE) Configuration of Transistor

In this configuration, the emitter terminal is common between the input and the output terminals as shown by Figure 9. This configuration offers medium input impedance, medium output impedance, medium current gain and voltage gain.

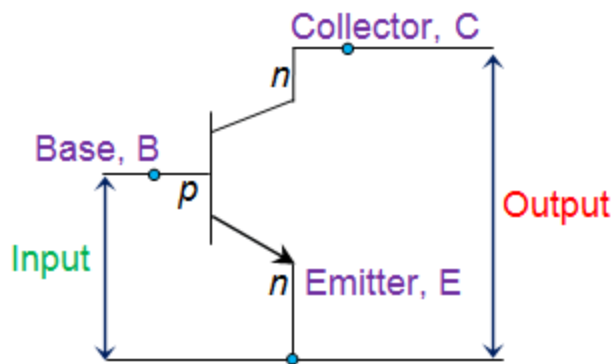

Input Characteristics for CE Configuration of Transistor

Figure 10 shows the input characteristics for the CE configuration of transistor which illustrates the variation in I_B in accordance with V_{BE} when V_{CE} is kept constant.

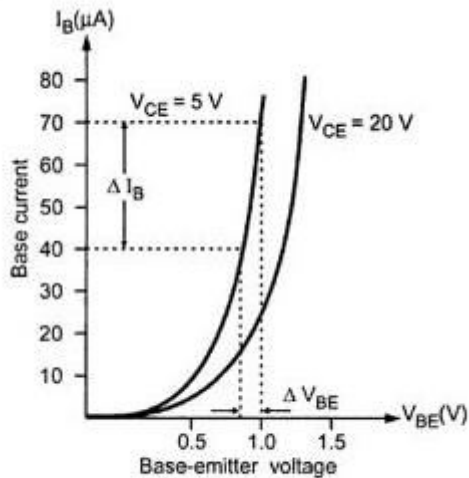

Fig 3.2: Input characteristics of the transistor in CE configuration

From the graph shown in Figure 10 above, the input resistance of the transistor can be obtained as

$$R_{in} = \left. \frac{\Delta V_{BE}}{\Delta I_B} \right|_{V_{CE} = \text{constant}}$$

Output Characteristics for CE Configuration of Transistor

The output characteristics of CE configuration (Figure 11) are also referred to as collector characteristics. This plot shows the variation in I_C with the changes in V_{CE} when I_B is held constant. From the graph shown, the output resistance can be obtained as:

$$R_{out} = \left. \frac{\Delta V_{CE}}{\Delta I_C} \right|_{I_E = \text{constant}}$$

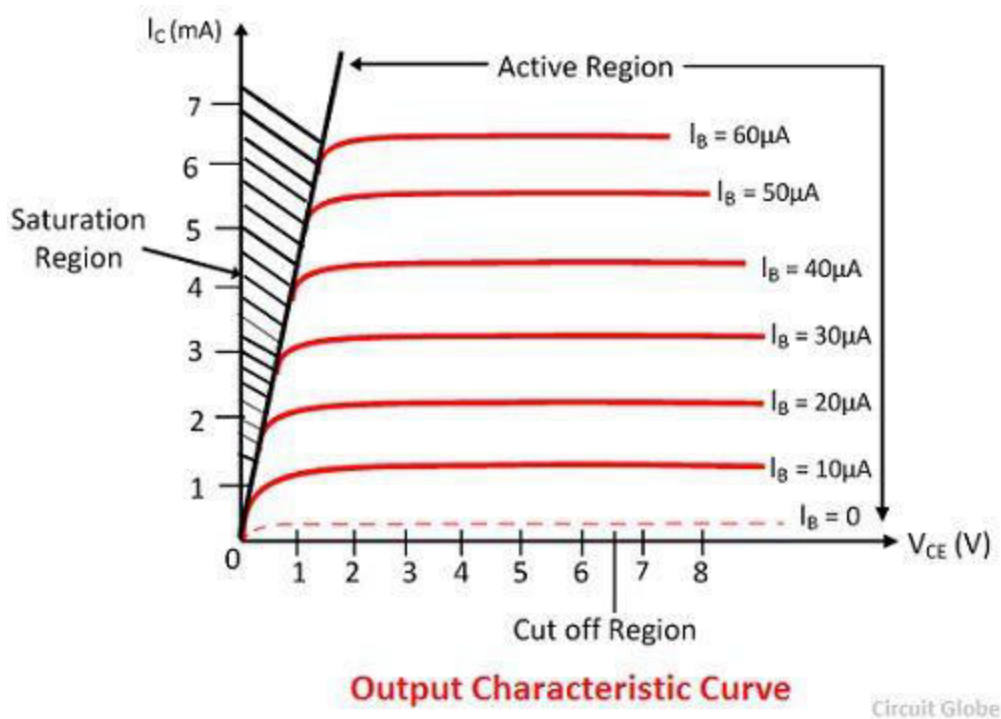

MODULE 5

BLOCK DIAGRAM DESCRIPTION OF A DC POWER SUPPLY

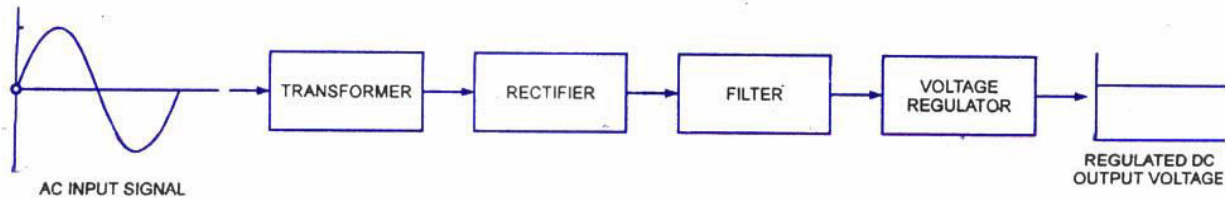

Block Diagram of a DC Power Supply

The electrical power is almost exclusively generated, transmitted and distributed in the form of ac because of economical consideration but for operation of most of the electronic devices and circuits, dc supply is required. Dry cells and batteries can be used for this purpose. No doubt, they have the advantages of being portable and ripple free but their voltages are low, they need frequent replacement and are expensive in comparison to conventional dc power supplies.

Now a days, almost all electronic equipment include a circuit that converts ac supply into dc supply. The part of equipment that converts ac into dc is called DC power supply. In general at the input of the power supply there is a power transformer. It is followed by a rectifier (a diode circuit) a smoothing filter and then by a *voltage* regulator circuit.

From the block diagram, the basic power supply is constituted by four elements viz a *transformer*, a *rectifier*, a *filter*, and a *regulator* put together. The output of the dc power supply is used to provide a constant dc voltage across the load. Let us briefly outline the function of each of the elements of the dc power supply.

Transformer is used to step-up or step-down (usually to step-down) the-supply voltage as per need of the solid-state electronic devices and circuits to be supplied by the dc power supply. It can provide isolation from the supply line-an important safety consideration. It may also include internal shielding to prevent unwanted electrical noise signal on the power line from getting into the power supply and possibly disturbing the load.

Rectifier is a device which converts the sinusoidal ac voltage into either positive or negative pulsating dc. P-N junction diode, which conducts when forward biased and practically does not conduct when reverse biased, can be used for rectification *i.e.* for conver-

sion of ac into dc. The rectifier typically needs one, two or four diodes. Rectifiers may be either half-wave rectifiers or full-wave rectifiers (centre-tap or bridge) type.

The output voltage from a rectifier circuit has a pulsating character i.e., it contains unwanted ac components (components of supply frequency f and its harmonics) along with dc component. For most supply purposes, constant direct voltage is required than that furnished by a rectifier. To reduce ac components from the rectifier output voltage a *filter circuit is required*.

Thus filter is a device which passes dc component to the load and blocks I ac components of the rectifier output. Filter is typically constructed from reactive circuit I elements such as capacitors and/or inductors and resistors. The magnitude of output dc voltage may vary with the variation of either the input ac voltage or the magnitude of load current. So at the output of a rectifier filter combination a voltage regulator is required, to provide an almost constant dc voltage at the output of the regulator. The voltage regulator may be constructed from a Zener diode, and or discrete transistors, and/or integrated circuits (ICs). Its main function is to maintain a constant dc output voltage. However, it also rejects any ac ripple voltage that is not removed by the filter. The regulator may also include protective devices such as short-circuit protection, current limiting, thermal shutdown, or over-voltage protection.

WORKING OF A FULL WAVE BRIDGE RECTIFIER

FULL-WAVE RECTIFICATION

Bridge Rectifier

The dc level obtained from a sinusoidal input can be improved 100% using a process called full-wave rectification. The most familiar network for performing such a function appears in Fig. 2.52 with its four diodes in a bridge configuration. During the period $t = 0$ to $T/2$ the polarity of the input is as shown in Fig. 2.53. The resulting polarities across the ideal diodes are also shown in Fig. 2.53 to reveal that D2 and D3 are conducting while D1 and D4 are in the “off” state. The net result is the configuration of Fig. 2.54, with its indicated current and polarity across R. Since the diodes are ideal the load voltage is $V_o = V_i$, as shown in the same figure

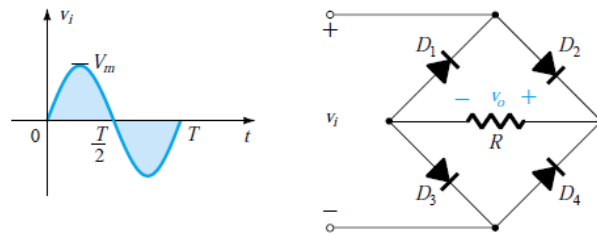

Figure 2.52 Full-wave bridge rectifier.

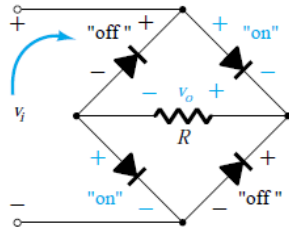

Figure 2.53 Network of Fig. 2.52 for the period $0 \rightarrow T/2$ of the input voltage v_i .

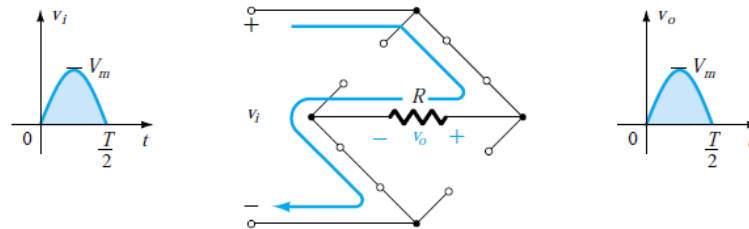

Figure 2.54 Conduction path for the positive region of v_i .

For the negative region of the input the conducting diodes are D_1 and D_4 , resulting in the configuration of Fig. 2.55. The important result is that the polarity across the load resistor R is the same as in Fig. 2.53, establishing a second positive pulse, as shown in Fig. 2.55. Over one full cycle the input and output voltages will appear as shown in Fig. 2.56.

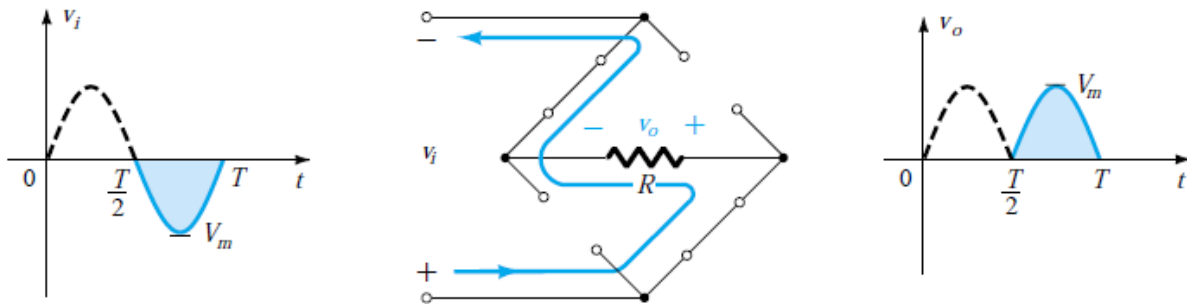

Figure 2.55 Conduction path for the negative region of v_i .

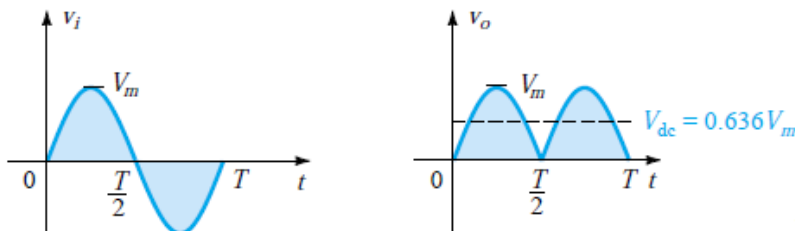
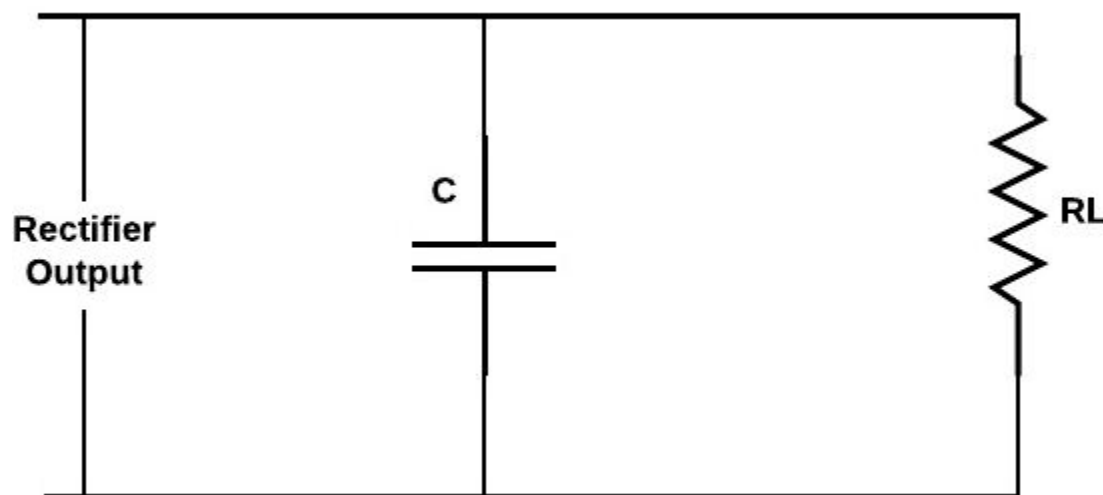

Figure 2.56 Input and output waveforms for a full-wave rectifier.

Parameters	Center tapped full wave rectifier	Bridge rectifier
Number of diodes	2	4
Maximum efficiency	81.2%	81.2%
Peak inverse voltage	$2V_m$	V_m
Vdc(no load)	$2V_m/\pi$	$2V_m/\pi$
Transformer utilization factor	0.693	0.812
Ripple factor	0.48	0.48
Form factor	1.11	1.11
Peak factor	$\sqrt{2}$	$\sqrt{2}$
Average current	$I_{dc}/2$	$I_{dc}/2$
Output frequency	$2f$	$2f$

CAPACITOR FILTER

A typical **capacitor filter** circuit diagram is shown below. The designing of this circuit can be done with [a capacitor \(C\)](#) as well as load resistor (RL). The rectifier's exciting voltage is given across the terminals of a capacitor. Whenever the voltage of the rectifier enhances then the capacitor will be charged as well as supplies the current to the load.



At the last part of the quarter phase, the capacitor will be charged to the highest rectifier voltage value that is denoted with V_m , and then the voltage of the rectifier starts to reduce. As this happens, the capacitor starts discharging through the voltage across it and load. The voltage across the load will reduce little only because the next peak voltage

occurs instantaneously to charge the capacitor. This procedure will repeat many times and the output waveform will be seen that very slight ripple is missing in the output. Furthermore, the output voltage is superior because it remains significantly close to the highest value of the output voltage of the rectifier.

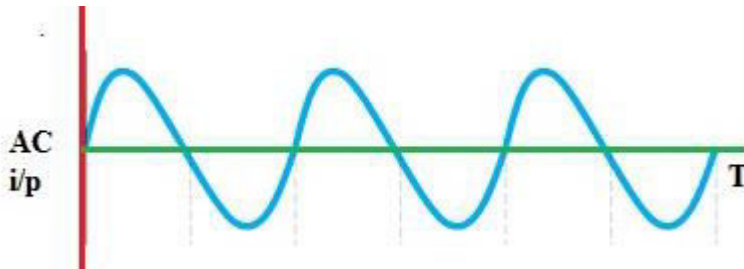

Figure: AC input waveform

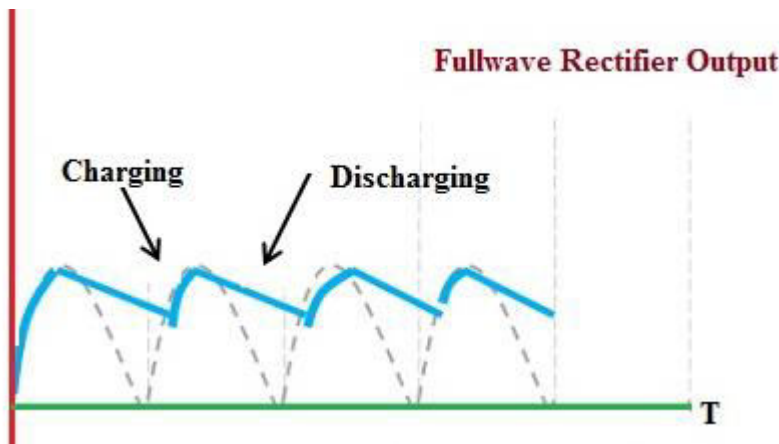

Figure: Output waveform using capacitor filter

A capacitor gives an infinite reactance to DC .For DC, $f=0$

$$X_c = 1 / 2\pi f c = 1 / 2\pi \times 0 \times C = \text{infinite}$$

Therefore, a capacitor doesn't permit DC to flow through it.

The capacitor filter circuit is very famous due to its features like low cost, less weight, small size, & good characteristics. The capacitor filter circuit is applicable for small load currents.

WORKING OF SIMPLE ZENER VOLTAGE REGULATOR

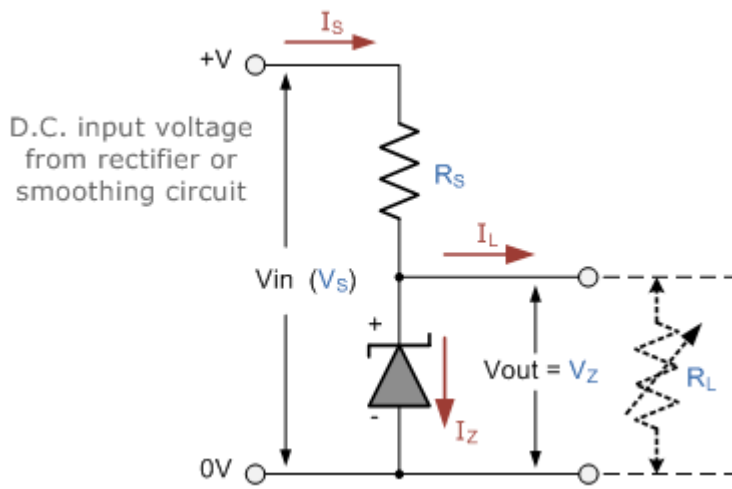

Resistor, R_S is connected in series with the zener diode to limit the current flow through the diode with the voltage source, V_S being connected across the combination. The stabilised output voltage V_{out} is taken from across the zener diode.

The zener diode is connected with its cathode terminal connected to the positive rail of the DC supply so it is reverse biased and will be operating in its breakdown condition. Resistor R_S is selected so to limit the maximum current flowing in the circuit.

With no load connected to the circuit, the load current will be zero, ($I_L = 0$), and all the circuit current passes through the zener diode which in turn dissipates its maximum power. Also a small value of the series resistor R_S will result in a greater diode current when the load resistance R_L is connected and large as this will increase the power dissipation requirement of the diode so care must be taken when selecting the appropriate value of series resistance so that the zener's maximum power rating is not exceeded under this no-load or high-impedance condition.

The load is connected in parallel with the zener diode, so the voltage across R_L is always the same as the zener voltage, ($V_R = V_Z$). There is a minimum zener current for which the stabilisation of the voltage is effective and the zener current must stay above this value operating under load within its breakdown region at all times. The upper limit of current is of course dependant upon the power rating of the device. The supply voltage V_S must be greater than V_Z .

One small problem with zener diode stabiliser circuits is that the diode can sometimes generate electrical noise on top of the DC supply as it tries to stabilise the voltage.

Normally this is not a problem for most applications but the addition of a large value decoupling capacitor across the zener's output may be required to give additional smoothing.

Then to summarise a little. A zener diode is always operated in its reverse biased condition. As such a simple voltage regulator circuit can be designed using a zener diode to maintain a constant DC output voltage across the load in spite of variations in the input voltage or changes in the load current.

The zener voltage regulator consists of a current limiting resistor R_S connected in series with the input voltage V_S with the zener diode connected in parallel with the load R_L in this reverse biased condition. The stabilised output voltage is always selected to be the same as the breakdown voltage V_Z of the diode.

BLOCK DIAGRAM OF PUBLIC ADDRESS SYSTEM

PA system is an **electronic sound amplification and distribution system** with a microphone, amplifiers and loudspeakers used in many applications such as addressing a large public, announcements in offices and institutions etc.

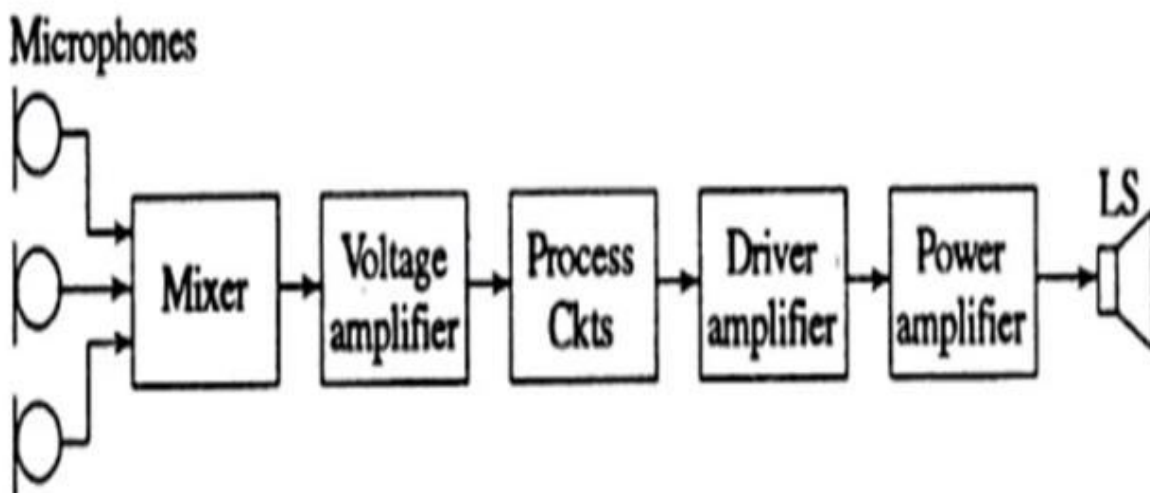

- Microphone :- Its pick up a sound wave and convert them into electrical variation, called sound signal.
- Mixer:- It is for effectively isolate different channels from each other before feeding to the main amplifier.
- Voltage amplifier:- Its amplifies the output of the mixer.
- Processing circuit:- This circuit have master gain control and tone control (bass and treble control).
- Driver amplifier:- It gives voltage amplification to such extent that internal resistance of that stage is reduced. thus, it drives the power amplifier to give more power.
- Power amplifier:- It gives the desire power amplification to the signal.
- Loudspeaker:- It converts electrical audio signal into pressure variation resulting in sound.

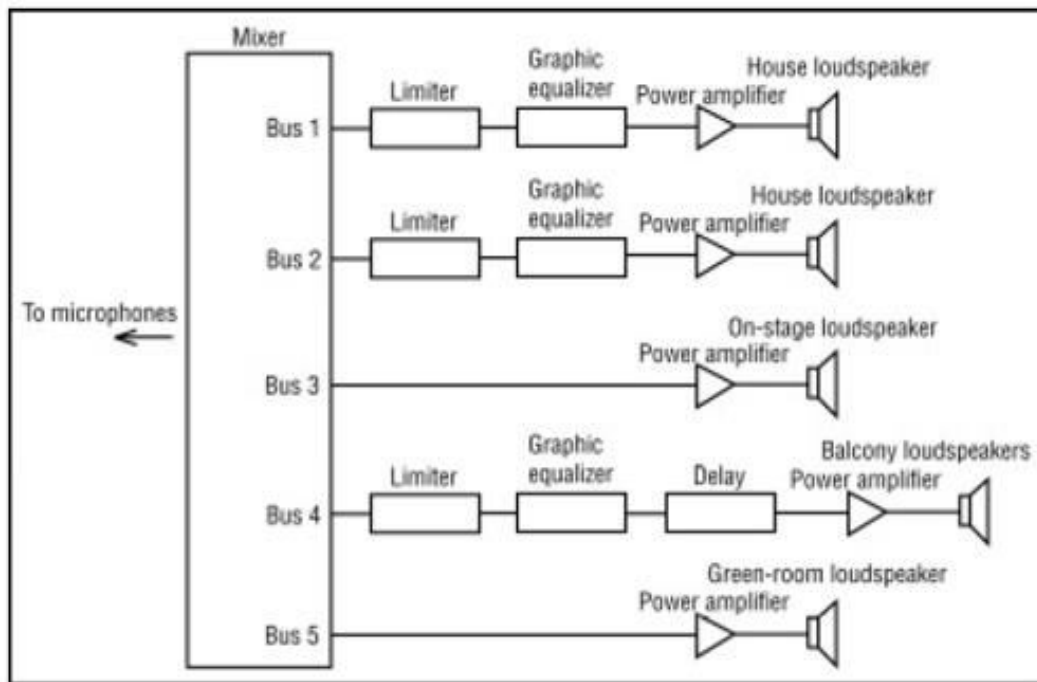

- **Equalization** is the process of altering the frequency response of an audio system using filters.
- It adjusts the amplitude of audio signals at particular frequencies.
- **Equalization may also be used to eliminate unwanted signals, make certain instruments or voices more prominent.**
- **Graphic equalizer:-** allows the user to see graphically and control individually a number of different frequency bands.
- Low frequency (popularly called bass) of the signal is amplified and converted into audio using low frequency speakers (popularly called woofers).
- Similarly high frequency audio signals are amplified and fed to high frequency loud speakers.

RC Coupled Amplifier

A **Resistance Capacitance (RC) Coupled Amplifier** is basically a multi-stage amplifier circuit extensively used in electronic circuits. Here the individual stages of the amplifier are connected together using a resistor-capacitor combination due to which it bears its name as RC Coupled.

Figure 1 shows such a two-stage amplifier whose individual stages are nothing but the common emitter amplifiers. Hence the design of individual stages of the **RC coupled amplifiers** is similar to that in the case of common emitter amplifiers in which the resistors R_1 and R_2 form the biasing network while the emitter resistor R_E form the stabilization network. Here the C_E is also called bypass capacitor which passes only AC while restricting DC, which causes only DC voltage to drop across R_E while the entire AC voltage will be coupled to the next stage.

Further, the coupling capacitor C_C also increases the stability of the network as it blocks the DC while offers a low resistance path to the AC signals, thereby preventing the DC bias conditions of one stage affecting the other. In addition, in this circuit, the voltage drop across the collector-emitter terminal is chosen to be 50% of the supply voltage V_{CC} in order to ensure appropriate biasing point.

In this kind of amplifier, the input signal applied at the base of the transistor in stage 1 (Q_1) is amplified and appears at its collector terminal with a phase-shift of 180° . The AC component of this signal is coupled to the second stage of the **RC coupled amplifier** through the coupling capacitor C_C and thus appears as an input at the base of the second transistor Q_2 . This is further amplified and is passed-on as an output of the second stage and is available at the collector terminal of Q_2 after being shift by 180° in its phase. This means that the output of the second stage will be 360° out-of-phase with respect to the input, which inturn indicates that the phase of the input signal and the phase of the output signal obtained at stage II will be identical.

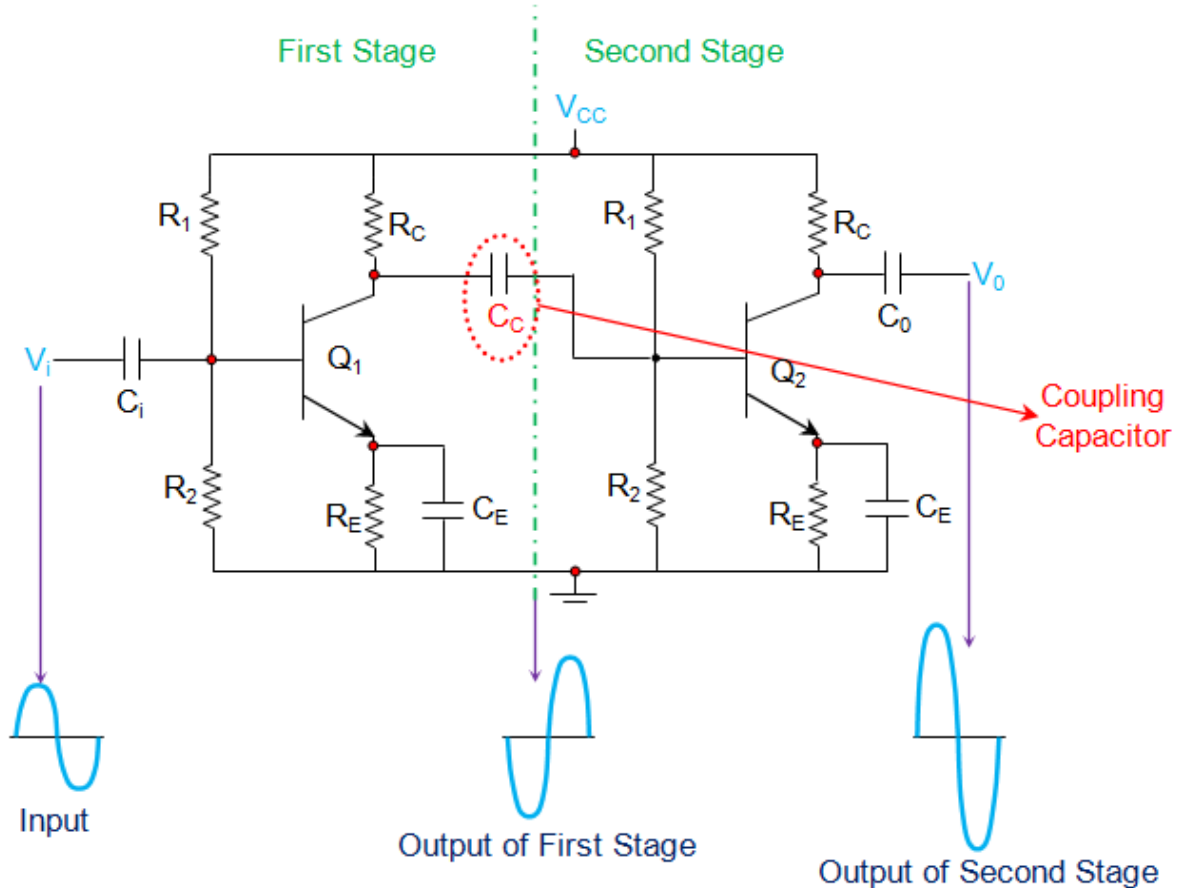

Figure 1 Two-Stage RC Coupled Amplifier

Further it is to be noted that the cascading of individual amplifier stages increases the gain of the overall circuit as the net gain will be the product of the gain offered by the individual stages. However in real scenario, the net gain will be slightly less than this, due to the loading effect. In addition, it is important to note that by following the pattern exhibited by Figure 1, one can cascade any number of common emitter amplifiers but by keeping in mind that when the number of stages are even, the output will be in-phase

with the input while if the number of stages are odd, then the output and the input will be out-of-phase.

Frequency Response of RC Coupled Amplifier

Frequency response curve is a graph that indicates the relationship between voltage gain and function of frequency. The frequency response of a RC coupled amplifier is as shown in the following graph.

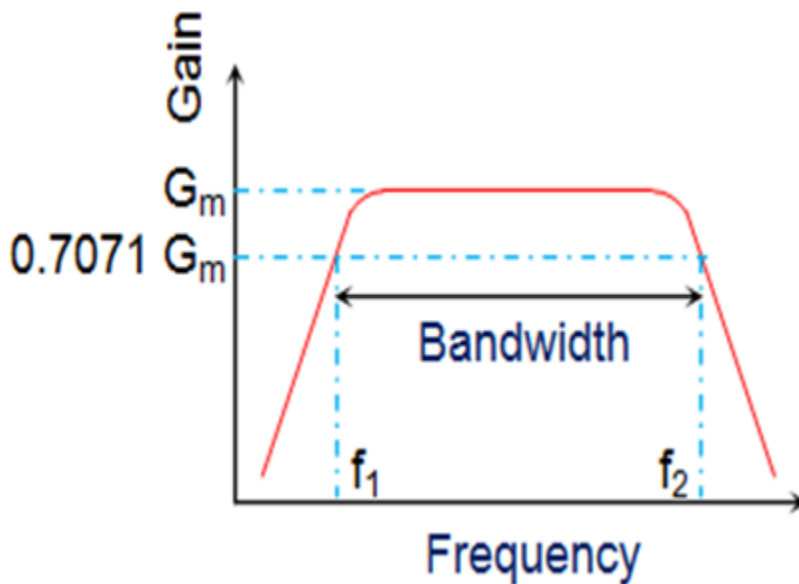

From the above graph, it is understood that the frequency rolls off or decreases for the frequencies below F_1 and for the frequencies above F_2 . Whereas the voltage gain for the range of frequencies between F_1 and F_2 is constant.

We know that,

$$X_C = 1/2\pi f c$$

It means that the capacitive reactance is inversely proportional to the frequency

At Low frequencies (i.e. below 50 Hz)

The capacitive reactance is inversely proportional to the frequency. At low frequencies, the reactance is quite high. The reactance of input capacitor C_{in} and the coupling capacitor C_C are so high that only small part of the input signal is allowed. The reactance of the emitter by pass capacitor C_E is also very high during low frequencies. Hence it

cannot shunt the emitter resistance effectively. With all these factors, the voltage gain rolls off at low frequencies.

At High frequencies (i.e. above 20 KHz)

Again considering the same point, we know that the capacitive reactance is low at high frequencies. So, a capacitor behaves as a short circuit, at high frequencies. As a result of this, the loading effect of the next stage increases, which reduces the voltage gain. Along with this, as the capacitance of emitter diode decreases, it increases the base current of the transistor due to which the current gain (β) reduces. Hence the voltage gain rolls off at high frequencies.

At Mid-frequencies (i.e. 50 Hz to 20 KHz)

The voltage gain of the capacitors is maintained constant in this range of frequencies, as shown in figure. If the frequency increases, the reactance of the capacitor C_C decreases which tends to increase the gain. But this lower capacitance reactive increases the loading effect of the next stage by which there is a reduction in gain.

Due to these two factors, the gain is maintained constant.

Advantages of RC Coupled Amplifier

The following are the advantages of RC coupled amplifier.

- The frequency response of RC amplifier provides constant gain over a wide frequency range, hence most suitable for audio applications.
- The circuit is simple and has lower cost because it employs resistors and capacitors which are cheap.
- It becomes more compact with the upgrading technology.

Disadvantages of RC Coupled Amplifier

The following are the disadvantages of RC coupled amplifier.

- The voltage and power gain are low because of the effective load resistance.
- They become noisy with age.
- Due to poor impedance matching, power transfer will be low.

Applications of RC Coupled Amplifier

The following are the applications of RC coupled amplifier.

- They have excellent audio fidelity over a wide range of frequency.
- Widely used as Voltage amplifiers
- Due to poor impedance matching, RC coupling is rarely used in the final stages.

CONCEPT OF VOLTAGE DIVIDER BIASING

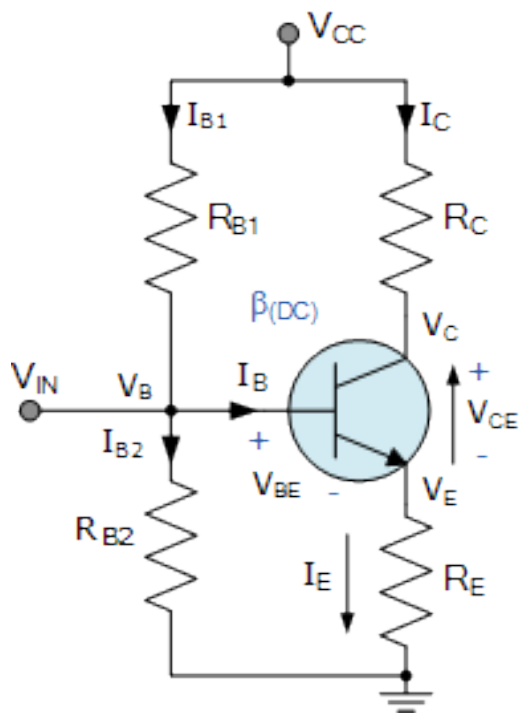

$$\begin{aligned}
 V_C &= V_{CC} - R_C I_C = (V_E + V_{CE}) \\
 V_E &= I_E R_E = V_B - V_{BE} \\
 V_{CE} &= V_C - V_E = V_{CC} - (I_C R_C + I_E R_E) \\
 V_B &= V_{BE} + V_E = V_{R_{B2}} = \left(\frac{R_{B2}}{R_{B1} + R_{B2}} \right) V_{CC} \\
 I_{B2} &= \frac{V_B}{R_{B2}} \\
 I_{B1} &= I_B + I_{B2} = \frac{V_{CC} - V_B}{R_{B1}} \\
 R_B &= \frac{R_{B1} \times R_{B2}}{R_{B1} + R_{B2}} \quad I_B = \frac{V_B - V_{BE}}{R_B + (1 + \beta) R_E} \\
 I_C &= \beta(DC) I_B \\
 I_E &= I_C + I_B = \frac{V_E}{R_E}
 \end{aligned}$$

Here the common emitter transistor configuration is biased using a voltage divider network to increase stability. The name of this biasing configuration comes from the fact that the two resistors R_{B1} and R_{B2} form a voltage or potential divider network across the supply with their center point junction connected to the transistor's base terminal as shown.

This voltage divider biasing configuration is the most widely used transistor biasing method. The emitter diode of the transistor is forward biased by the voltage value developed across resistor R_{B2} . Also, voltage divider network biasing makes the transistor circuit independent of changes in beta as the biasing voltages set at the transistor's base, emitter, and collector terminals are not dependent on external circuit values.

To calculate the voltage developed across resistor R_{B2} and therefore the voltage applied to the base terminal we simply use the voltage divider formula for resistors in series.

Generally the voltage drop across resistor R_{B2} is much less than for resistor R_{B1} . Clearly the transistors base voltage V_B with respect to ground, will be equal to the voltage across R_{B2} .

The amount of biasing current flowing through resistor R_{B2} is generally set to 10 times the value of the required base current I_B so that it is sufficiently high enough to have no effect on the voltage divider current or changes in Beta.

The goal of **Transistor Biasing** is to establish a known quiescent operating point, or Q-point for the bipolar transistor to work efficiently and produce an undistorted output signal. Correct DC biasing of the transistor also establishes its initial AC operating region with practical biasing circuits using either a two or four-resistor bias network.

In bipolar transistor circuits, the Q-point is represented by (V_{CE}, I_C) for the NPN transistors or (V_{EC}, I_C) for PNP transistors. The stability of the base bias network and therefore the Q-point is generally assessed by considering the collector current as a function of both Beta (β) and temperature.

Here we have looked briefly at five different configurations for “biasing a transistor” using resistive networks. But we can also bias a transistor using either silicon diodes, zener diodes or active networks all connected to the transistors base terminal. We could also correctly bias the transistor from a dual voltage power supply if so wished.

BLOCK DIAGRAM OF INSTRUMENTATION SYSTEM

It is branch of engineering which deals with various types of instrument to record, monitor, indicate and control various physical parameters such as pressure, temperature, etc.

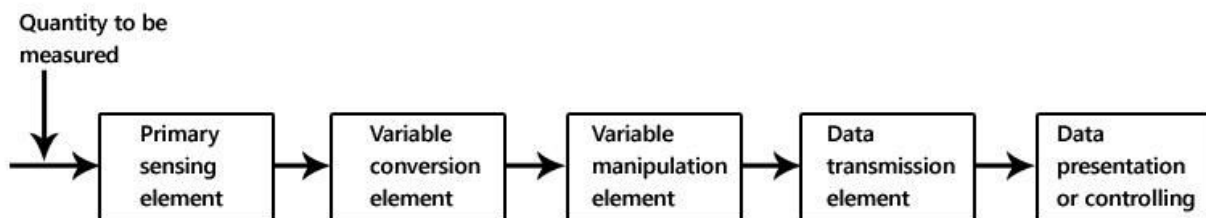

The block diagram shown above is of basic instrumentation system. It consist of primary sensing element, variable manipulation element, data transmission element and data presentation element.

Primary sensing element

The primary sensing element is also known as sensor. Basically transducers are used as a primary sensing element. Here, the physical quantity (such as temperature, pressure etc.) are sensed and then converted into analogues signal.

Variable conversion element

It converts the output of primary sensing element into suitable form without changing information. Basically these are secondary transducers.

Variable manipulation element

The output of transducer may be electrical signal i.e. voltage, current or other electrical parameter. Here, manipulation means change in numerical value of signal. This element is used to convert the signal into suitable range.

Data transmission element

Sometimes it is not possible to give direct read out of the quality at a particular place (Example – Measurement of temperature in the furnace). In such a case, the data should transfer from one place to another place through channel which is known as data transmission element. Typically transmission path are pneumatic pipe, electrical cable and radio links. When radio link is used, the electronic instrumentation system is called as telemetry system.

Data presentation or controlling element

Finally the output is recorded or given to the controller to perform action. It performs different functions like indicating, recording or controlling.

MODULE 6

EVOLUTION OF COMMUNICATION SYSTEMS

Just a few generations ago, our ancestors were dependent on what is now considered primitive communications technology. But it's all relative. Wired telegraphy that criss-crossed the United States was a major [breakthrough in innovation](#).

Wireless telegraphy in the form of radio made it possible to carry on a conversation without the use of cables. And improvements in radio communications through the years have only expanded the range of service capabilities. Fifth-generation mobile telephony, known simply as 5G, is the latest invention to thrill and amaze the user.

A more recent telecommunications implementation was the use of semaphore by the French. In the 1700s, they built semaphore towers across the country, each at a distance of a few miles but still within sight. Using mechanically controlled flags, a French communications technician could pass messages along to the next tower. Using this method, a message could be transmitted across the country in short order.

These are just a couple of examples of wireless telecommunications (we left out carrier pigeon) that preceded the digital age. It was Guglielmo Marconi who pioneered the use of long-distance radio communication that forms the basis for all our current mobile telephony. At the heart of it all is the electromagnetic spectrum, which includes radio waves with frequencies ranging from 30 Hz to 300 GHz.

[Long before mobile telephony](#) was born, various technologies that it would employ were already in use. Push-to-talk (PTT) systems were being used by police and fire personnel. Powerful radio towers streamed news and entertainment across vast distances. AT&T offered a Mobile Telephone Service (MTS) as far back as 1949, and later introduced its Improved Mobile Telephone Service (IMTS) in 1965. Some people have given the name 0G to these mobile network predecessors.

The birth of 1G was a little more obvious. Nippon Telegraph and Telephone (NTT) in Japan rolled out the first generation (1G) of mobile telephony in 1979. Systems from other carriers were quickly to follow. There was an implementation of 1G by Nordic Mobile Telephone in 1981, standards such as Advance Mobile Phone System (AMPS) by Bell Labs in 1982 and C450 in Germany were propagated worldwide.

Second-generation (2G) was started in Finland in 1991. It was based on the GSM standard, and included the introduction of text messaging known as short message service (SMS), as well as other services. Later developments of 2G included general packet radio service (GPRS) and Enhanced Data Rates for GSM Evolution (EDGE).

With the advent of 3G, things started to get interesting. The internet boom of the late 1990s created a demand for users to go online with their mobile phones. The 3rd Generation Partnership Project (3GPP) was formed in 1998 to develop protocols and standards for 3G. It was a group effort by organizations from around the world. The result was the introduction of robust technologies, such as Wideband Code Division Multiple Access (WCDMA) and High Speed Packet Access (HSPA), that made web access at high speeds and capacities possible.

4G, known as Long-term Evolution (LTE), was a whole restructuring of mobile telephony. It was a new way of doing mobile. In fact, they gave the name Systems Architecture Evolution (SAE) to its core network. The Evolved Packet Core (EPC) includes the mobile management entity (MME), the serving gateway (SGW), the PDN gateway (PGW), and the home subscriber server (HSS). On the radio side, the eNodeB takes signals received through the air interface from mobile handsets and transmits them through network interfaces to the core network. LTE took wireless telephony to a whole new level of sophistication.

And now 5G is upon us. Verizon has already started to roll out its 5G Home and its 5G Mobile. Other carriers are hot on their heels. Like 4G, 5G promises to be [a whole new rethink of wireless](#). The final publication of standards is slated for next year as part of the IMT-2020 Vision created by the ITU-T and 3GPP. But it won't be entirely new. 5G will borrow and build upon technologies from previous generations.

5G is the fifth generation wireless technology for [digital cellular networks](#) that began wide deployment in 2019. As with previous standards, the covered areas are divided into regions called "cells", serviced by individual antennas. Virtually every major telecommunication service provider in the developed world is deploying antennas or intends to deploy them soon. The [frequency spectrum](#) of 5G is divided into millimeter waves, mid-band and low-band. Low-band uses a similar frequency range as the predecessor, [4G](#).

RADIO COMMUNICATION:

NEED FOR MODULATION

- It is because modulation makes the information **signal more compatible** with the medium.
- **Modulation** = Imposing information at low frequency onto a higher frequency signal.
- A technique for transmitting information efficiently from one place to another.
- Simplest form of modulation is the amplitude modulation.

PRINCIPLES OF AM

- AM is defined as:
 - **Amplitude of carrier frequency change** proportionately to the value of the **modulation signal**.
- Advantages:
 - **Simple** modulator circuits
 - **Cheap** :low-quality form of modulation used for commercial broadcasting of audio & video signal.
- Disadvantages:
 - **Poor performance** due to noise
 - **Inefficient** use of transmitter power.
- Application:
 - 2 way radio communications, broadcasting, aircraft comm. & citizen band (CB) radio.

- AM modulators are nonlinear devices
 - 2 input and 1 output: modulating signal and carrier signal.

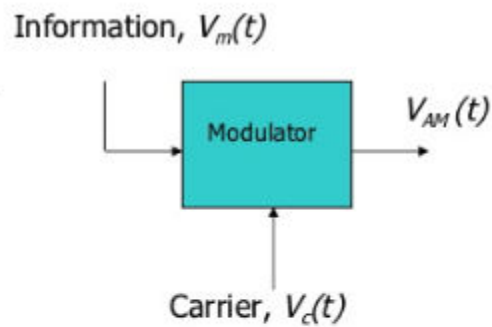

- Several types of amplitude modulation
 - AM DSBFC
 - DSB-SC
 - SSB

Figure 2.1: Block diagram of Amplitude Modulation

- AM generation is shown in Figure 2.1

- Modulated wave = AM envelope as shown in Figure 2.2

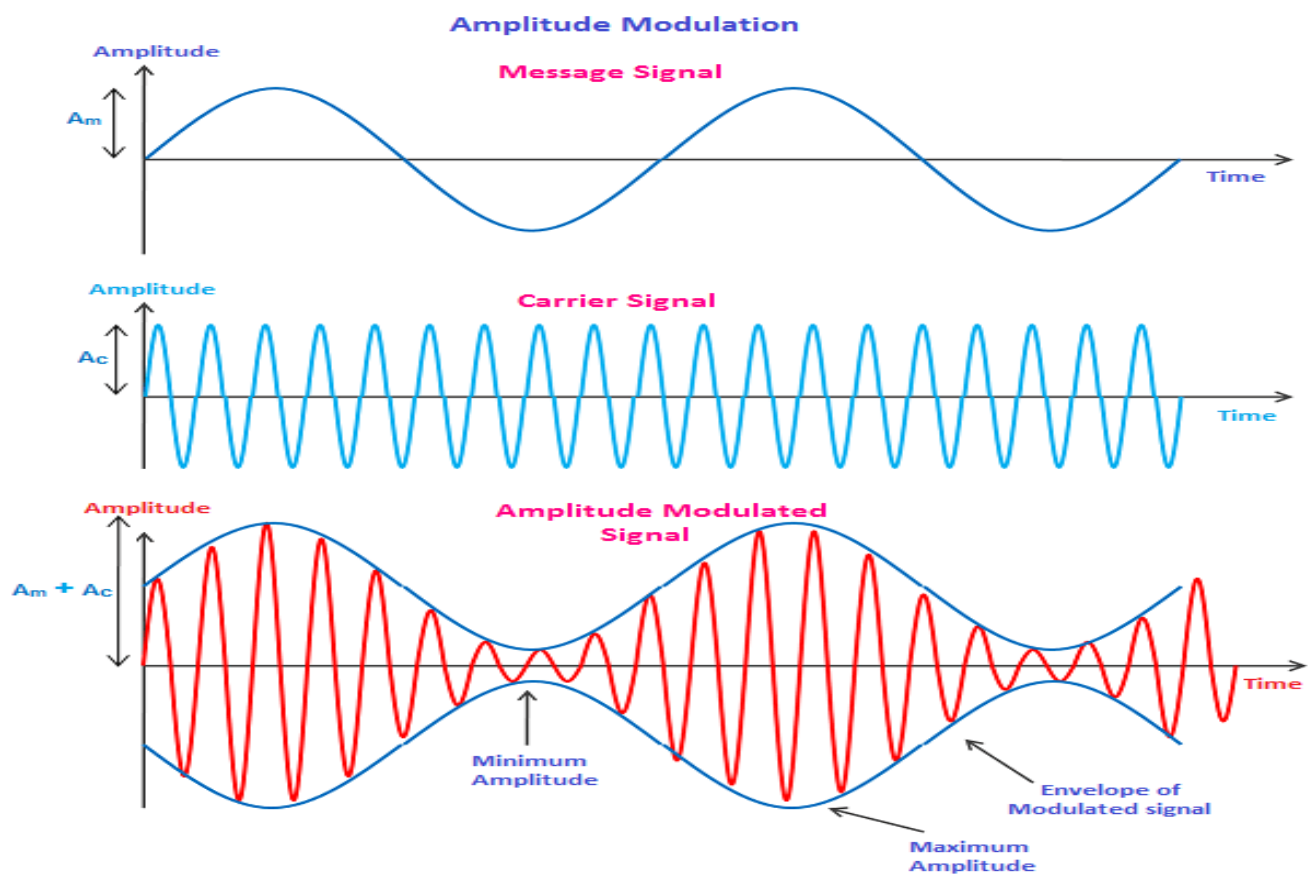

DERIVATION OF AM EQUATION

- AM begins with carrier v_c , \rightarrow a sine wave with frequency f_c & amplitude V_c :

$$v_c = V_c \sin 2\pi f_c t$$
- Modulating signal:

$$v_m = V_m \sin 2\pi f_m t$$
- Then AM is:

$$V_{env} = V_c + v_m$$

$$V_{env} = V_c + V_m \sin 2\pi f_m t \quad [m = V_m / V_c]$$

$$V_{env} = V_c + m V_c \sin 2\pi f_m t$$
- Where m (modulation index) is defined as V_m / V_c hence:

$$V_{env} = V_c (1 + m \sin 2\pi f_m t)$$
- The voltage resulting AM wave envelope at any instant is:

$$v = V_{env} \sin 2\pi f_c t$$

$$= V_c (1 + m \sin 2\pi f_m t) \cdot \sin 2\pi f_c t$$

Using Trigo ID

$$(\sin a)(\sin b) = 1/2[\cos(a-b) - \cos(a+b)]$$

$$v = V_c \sin 2\pi f_c t$$

$$+ \frac{m}{2} V_c \cos 2\pi(f_c - f_m)t$$

$$- \frac{m}{2} V_c \cos 2\pi(f_c + f_m)t$$

$$v_{AM} = V_c \sin 2\pi f_c t + \frac{V_m}{2} \cos 2\pi(f_c - f_m)t - \frac{V_m}{2} \cos 2\pi(f_c + f_m)t$$

↑
Carrier

↑
LSB

↑
USB

- This yield, the upper and lower sidebands – frequency & amplitude.

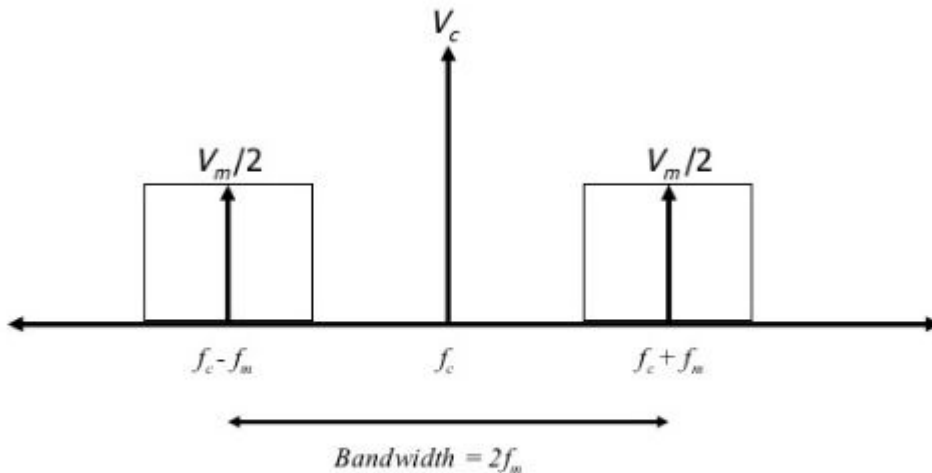
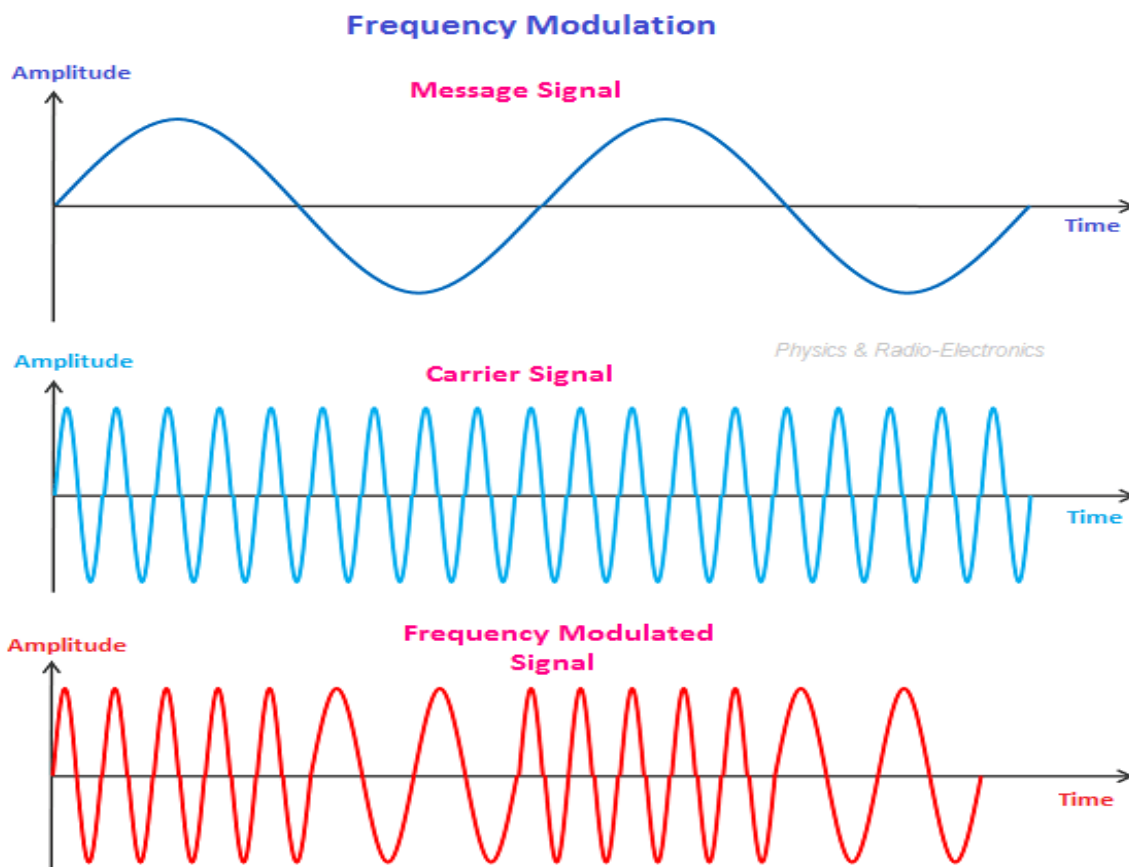

Figure 2.3: Frequency spectrum for AM wave

Principles of FM

- A sine wave carrier can be modified for the purpose of transmitting information from one place to another by varying its frequency. This is known as **frequency modulation (FM)**.
- In FM, the carrier amplitude remains constant and the carrier frequency is changed by the modulating signal

- **Frequency deviation (f_d)** is the amount of change in carrier frequency produced by the modulating signal.
- The **frequency deviation rate** is how many times per second the carrier frequency deviates above or below its center frequency.
- The frequency of the modulating signal determines the frequency deviation rate.
- A type of modulation called **frequency-shift keying (FSK)** is used in transmission of binary data in digital cell phones and low-speed computer modems.



Mathematical analysis of FM

- Mathematical analysis:
- Let message signal:

$$v_m(t) = V_m \cos \omega_m t$$

- And carrier signal:

$$v_c(t) = V_c \cos[\omega_c t + \theta]$$

- During the process of frequency modulations the frequency of carrier signal is changed in accordance with the instantaneous amplitude of message signal. Therefore the frequency of carrier after modulation is written as

- $\omega_i = \omega_c + K_1 v_m(t) = \omega_c + K_1 V_m \cos \omega_m t$
To find the instantaneous phase angle of modulated signal, integrate equation above w.r.t. t

$$\phi_i = \int \omega_i dt = \int (\omega_c + K_1 V_m \cos \omega_m t) dt = \omega_c t + \frac{K_1 V_m}{\omega_m} \sin \omega_m t$$

- Thus, we get the FM wave as:

$$v_{FM}(t) = V_c \cos \phi_1 = V_c \cos(\omega_c t + \frac{K_1 V_m}{\omega_m} \sin \omega_m t)$$

$$v_{FM}(t) = V_c \cos(\omega_c t + m_f \sin \omega_m t)$$

- Where modulation index for FM is given by

$$m_f = \frac{K_1 V_m}{\omega_m}$$

- Therefore:

$$\Delta f = K_1 V_m ;$$

$$m_f = \frac{\Delta f}{f_m}$$

- K_1 – deviation sensitivities Hz/V

FREQUENCY BAND USED FOR VARIOUS COMMUNICATION

Frequency Band	Frequency	Frequency Band Use
Radio and Broadcast	600 kHz to 1.6 MHz	AM radio
	88 to 108 MHz	FM radio
	54 to 700 MHz	TV broadcast

Microwave	L band	1 to 2 GHz	Cell phones 0.9-2.4 GHz Microwave 2.4 GHz Wireless Data 2.4 GHz Radar 1-100 GHz
	S band	2 to 4 GHz	
	C band	4 to 8 GHz	
	X band	8 to 12 GHz	
	K _u band	12 to 18 GHz	
	K band	18 to 26.5 GHz	
	K _a band	26.5 to 40 GHz	
	Q band	30 to 50 GHz	
	U band	40 to 60 GHz	
	V band	50 to 75 GHz	
	E band	60 to 90 GHz	
	W band	75 to 110 GHz	
	F band	90 to 140 GHz	
D band	110 to 170 GHz		

Terahertz	1 to 10 THz	Bio-imaging
Infrared	300 to 400 THz	Remotes, night vision
Visible Light	400 to 800 THz	
Ultraviolet	800 THz to 30 PHz	Dental curing, tanning
X-ray	30 PHz to 30 EHz	Baggage screening
Gamma	> 30 EHz	PET imaging

SUPER HETERODYNE RECEIVER

A superheterodyne receiver uses frequency mixing to convert a received signal to a fixed intermediate frequency (IF) which can be more conveniently processed than the original radio carrier frequency. The word "super" refers to "super-sonic" (ultra-sonic today) meaning the IF frequency was superior to or above human hearing. Heterodyne means to mix two frequencies in a non linear device or translate one frequency to another. The name "Superheterodyne" receiver is sometimes shortened to "superhet".

The basic block diagram of a superheterodyne receiver is shown in the following figure. The way in which the receiver works can be seen by following the signal as it passes through the receiver.

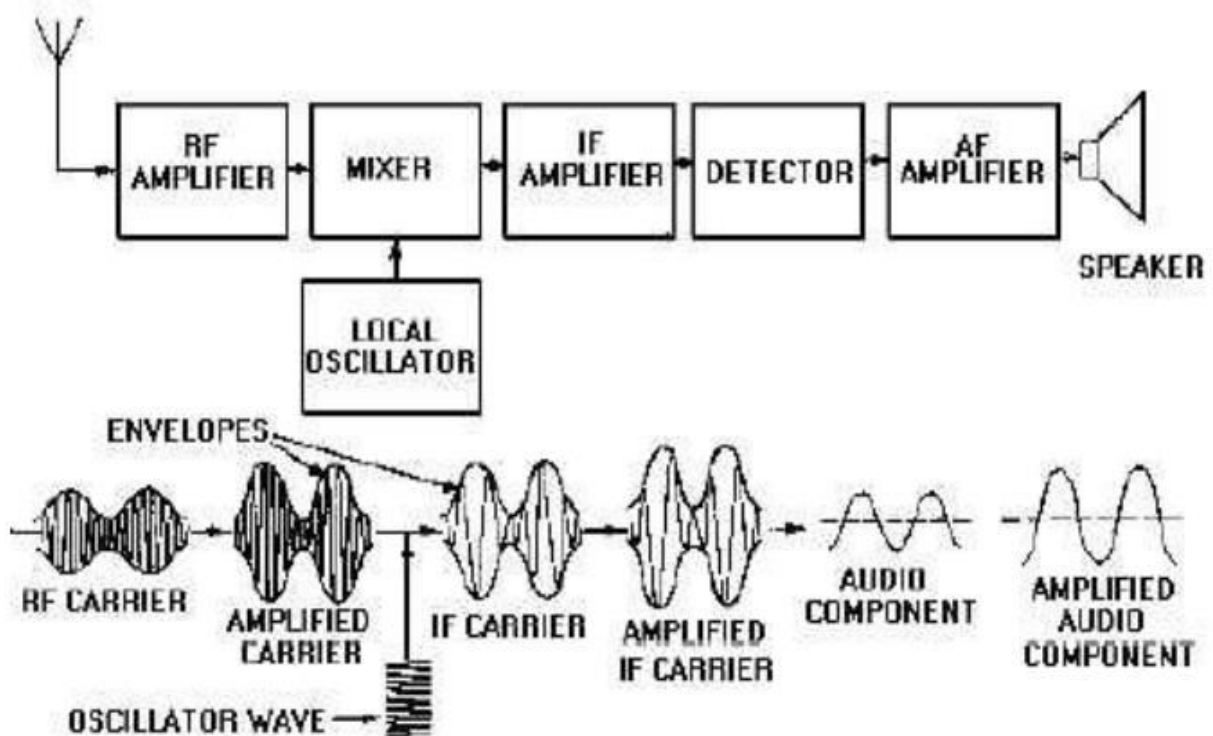

Fig: Block diagram of Superheterodyne Receiver

Front end amplifier and tuning block: Signals enter the front end circuitry from the antenna. This circuit block performs two main functions:

Tuning:- Broadband tuning is applied to the RF stage. The purpose of this is to reject the signals on the image frequency and accept those on the wanted frequency. It must also be able to track the local oscillator so that as the receiver is tuned, so the RF tuning remains on the required frequency. Typically the selectivity provided at this stage is not high. Its main purpose is to reject signals on the image frequency which is at a frequency equal to twice that of the IF away from the wanted frequency. As the tuning within this block provides all the rejection for the image response, it must be at a sufficiently sharp to reduce the image to an acceptable level. However the RF tuning may also help in preventing strong off-channel signals from entering the receiver and overloading elements of the receiver, in particular the mixer or possibly even the RF amplifier.

Amplification:- In terms of amplification, the level is carefully chosen so that it does not overload the mixer when strong signals are present, but enables the signals to be amplified sufficiently to ensure a good signal to noise ratio is achieved. The amplifier must also be a low noise design. Any noise introduced in this block will be amplified later in the receiver.

Mixer / frequency translator block: The tuned and amplified signal then enters one port of the mixer. The local oscillator signal enters the other port. The performance of the mixer is crucial to many elements of the overall receiver performance. It should be as linear as possible. If not, then spurious signals will be generated and these may appear as 'phantom' received signals.

Local oscillator: The local oscillator may consist of a variable frequency oscillator that can be tuned by altering the setting on a variable capacitor. Alternatively it may be a frequency synthesizer that will enable greater levels of stability and setting accuracy.

Intermediate frequency amplifier, IF block : Once the signals leave the mixer they enter the IF stages. These stages contain most of the amplification in the receiver as well as the filtering that enables signals on one frequency to be separated from those on the next. Filters may consist simply of LC tuned transformers providing inter-stage coupling, or they may be much higher performance ceramic or even crystal filters, dependent upon what is required.

Detector / demodulator stage: Once the signals have passed through the IF stages of the superheterodyne receiver, they need to be demodulated. Different demodulators are required for different types of transmission, and as a result some receivers may have a variety of demodulators that can be switched in to accommodate the different types of transmission that are to be encountered.

Audio amplifier: The output from the demodulator is the recovered audio. This is passed into the audio stages where they are amplified and presented to the headphones or loudspeaker.

PRINCIPLE OF ANTENNA – RADIATION FROM ACCELERATED CHARGE

Antenna is a source or radiator of Electromagnetic waves or a sensor of Electromagnetic waves. It is a transition device or transducer between a guided wave and a free space wave or vice versa. It is also an electrical conductor or system of conductors that radiates EM energy into or collects EM energy from free space. Antennas function by transmitting or receiving electromagnetic (EM) waves. Examples of these electromagnetic waves include the light from the sun and the waves received by your cell phone or radio. Your eyes are basically "receiving antennas" that pick up electromagnetic waves that are of a particular frequency. The colors that you see (red, green, blue) are each waves of different frequencies that your eyes can detect. All electromagnetic waves propagate at the same speed in air or in space. This speed (the speed of light) is roughly 671 million miles per hour (1 billion kilometers per hour). This is roughly a million times faster than the speed of sound (which is about 761 miles per hour at sea level). The speed of light will be denoted as c in the equations that follow. We like to use "SI" units in science (length measured in meters, time in seconds, mass in kilograms):

$$c = 3 \times 10^8 \text{ meter/second}$$

Some Antenna Types:

Wire Antennas- dipoles, loops and Helical

Aperture Antennas-Horns and reflectors

Array Antennas-Yagi, Log periodic

Patch Antennas- Microstrips, PIFAs

Basic Antenna Parameters:

A radio antenna may be defined as the structure associated with the region of transition between a guided wave and a free space wave or vice versa.

Principle:

Under time varying conditions, Maxwell's equations predict the radiation of EM energy from current source (or accelerated charge). This happens at all frequencies, but is insignificant as long as the size of the source region is not comparable to the wavelength. While transmission lines are designed to minimize this radiation loss, radiation into free space becomes main purpose in case of Antennas. The basic principle of radiation is produced by accelerated charge. The basic equation of radiation is

$$I L = Q V \text{ (Ams}^{-1}\text{)}$$

where,

I = Time changing current in Amps/sec

L = Length of the current element in meters

Q = Charge in Coulombs

V = Time changing velocity

Thus time changing current radiates and accelerated charge radiates. For steady state harmonic variation, usually we focus on time changing current. For transients or pulses, we focus on accelerated charge. The radiation is perpendicular to the acceleration and the radiated power is proportional to the square of IL or QV.

Transmission line opened out in a Tapered fashion as Antenna:

a). As Transmitting Antenna:

Here the Transmission Line is connected to source or generator at one end. Along the uniform part of the line energy is guided as Plane TEM wave with little loss. Spacing between line is a small fraction of λ . As the line is opened out and the separation between the two lines becomes comparable to λ , it acts like an antenna and launches a free space wave since currents on the transmission line flow out on the antenna but fields associated with them keep on going. From the circuit point of view the antennas appear to the transmission lines as a resistance R_r , called Radiation resistance.

b) As Receiving Antenna:

Active radiation by other Antenna or Passive radiation from distant objects raises the apparent temperature of R_r . This has nothing to do with the physical temperature of the

antenna itself but is related to the temperature of distant objects that the antenna is looking at. R_r may be thought of as virtual resistance that does not exist physically but is a quantity coupling the antenna to distant regions of space via a virtual transmission line.

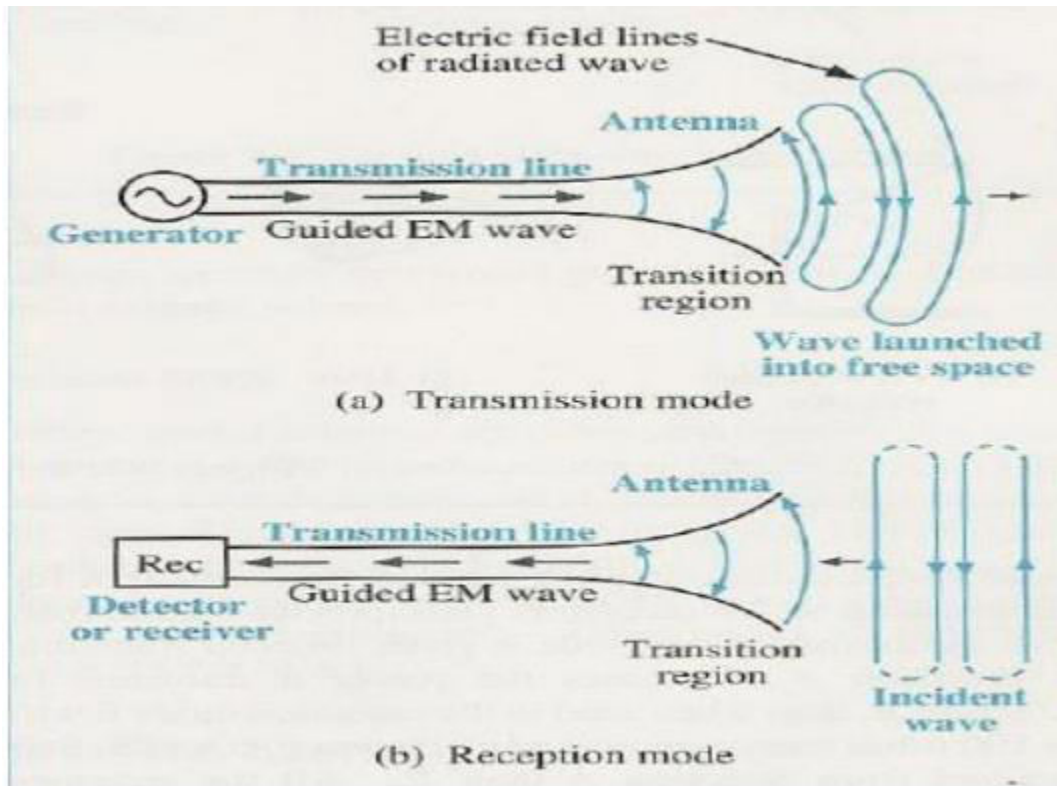

Thus, an antenna is a transition device, or transducer, between a guided wave and a free space wave or vice versa. The antenna is a device which interfaces a circuit and space.

MOBILE COMMUNICATION

Concepts of cells and Frequency reuse

In the cellular concept, frequencies allocated to the service are re-used in a regular pattern of areas, called 'cells', each covered by one base station. In mobile-telephone nets these cells are usually hexagonal. In radio broadcasting, a similar concept has been developed based on rhombic cells.

To ensure that the mutual interference between users remains below a harmful level, adjacent cells use different frequencies. In fact, a set of C different frequencies $\{f_1, \dots, f_C\}$ are used for each cluster of C adjacent cells. Cluster patterns and the corresponding frequencies are re-used in a regular pattern over the entire service area.

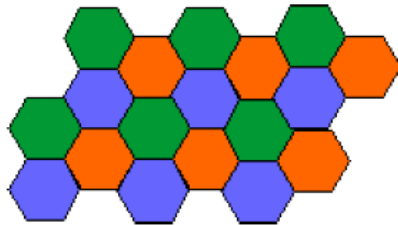

Real-World Cells

In the practice of cell planning, cells are not hexagonal as in the theoretical studies. Computer methods are being used for optimised planning of base station location and cell frequencies. Pathloss and link budgets are computed from the terrain features and antenna data. This determines to coverage of each base station and interference to other cells

Reuse Distance

The closest distance between the centres of two cells using the same frequency (in different clusters) is determined by the choice of the cluster size C and the lay-out of the cell cluster.

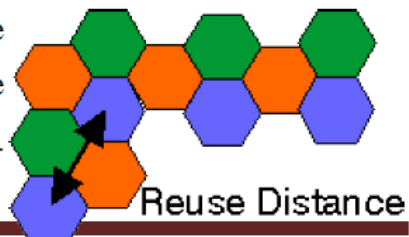

This distance is called the frequency 're-use' distance. It [can be shown](#) that the reuse distance r_u , normalised to the size of each hexagon, is

$$r_u = \text{SQRT}\{3 C\}$$

For hexagonal cells, i.e., with 'honeycomb' cell lay-outs commonly used in mobile radio, possible cluster sizes are $C = i^2 + ij + j^2$, with integer i and j ($C = 1, 3, 4, 7, 9, \dots$). Integers i and j determine the relative location of co-channel cells.

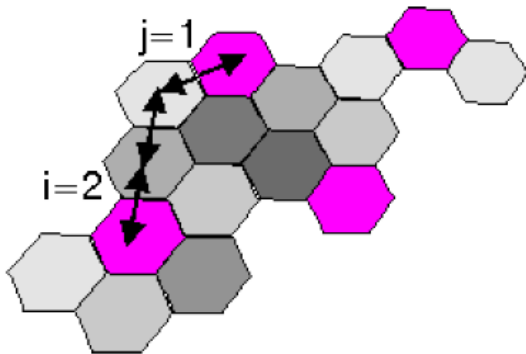

Cells

A cell is the basic geographic unit of a cellular system. The term cellular comes from the honeycomb shape of the areas into which a coverage region is divided. Cells are base stations transmitting over small geographic areas that are represented as hexagons. Each cell size varies depending on the landscape. Because of constraints imposed by natural terrain and man-made structures, the true shape of cells is not a perfect hexagon.

Clusters

A cluster is a group of cells. No channels are reused within a cluster.

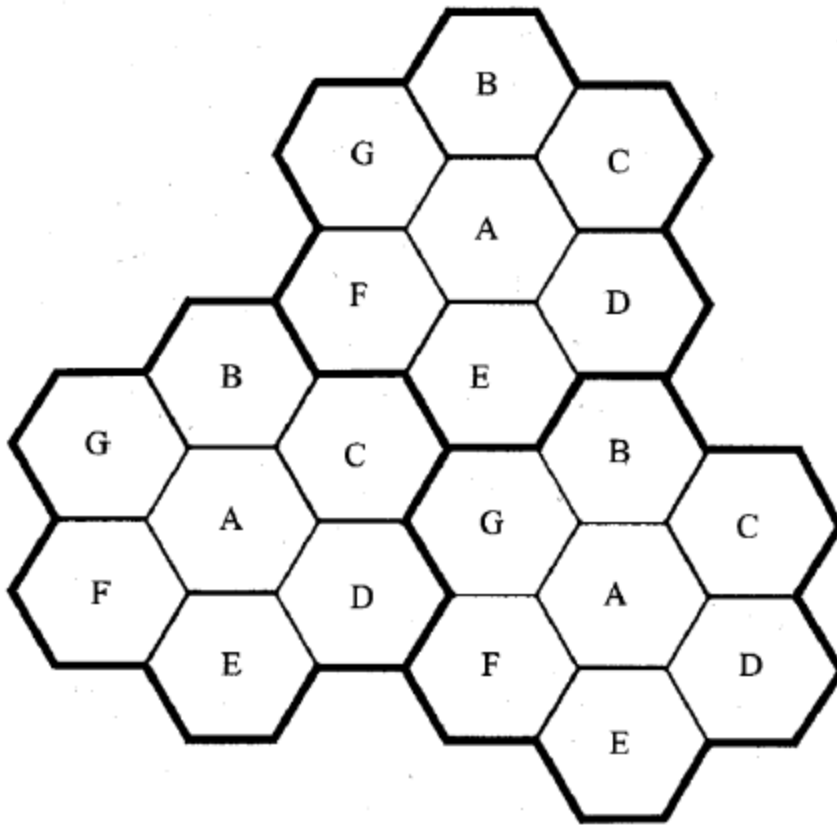

- seven groups of channel from A to G
- footprint of a cell - actual radio coverage
- omni-directional antenna v.s. directional antenna

Frequency Reuse

Because only a small number of radio channel frequencies were available for mobile systems, engineers had to find a way to reuse radio channels in order to carry more than one conversation at a time. The solution the industry adopted was called frequency planning or frequency reuse. Frequency reuse was implemented by restructuring the mobile telephone system architecture into the cellular concept. The concept of frequency reuse is based on assigning to each cell a group of radio channels used within a small geographic area. Cells are assigned a group of channels that is completely different from neighboring cells. The coverage area of cells are called the footprint. This footprint is limited by a boundary so that the same group of channels can be used in different cells that are far enough away from each other so that their frequencies do not interfere.

- Consider a cellular system which has a total of S duplex channels.
- Each cell is allocated a group of k channels,
- The S channels are divided among N cells.
- The total number of available radio channels
- The N cells which use the complete set of channels is called *cluster*.
- The cluster can be repeated M times within the system. The total number of channels, C , is used as a measure of capacity
- The capacity is directly proportional to the number of replication M .
- The cluster size, N , is typically equal to 4, 7, or 12.
- Small N is desirable to maximize capacity.
- The frequency reuse factor is given by
- Hexagonal geometry has
 - exactly six equidistance neighbors
 - the lines joining the centers of any cell and each of its neighbors are separated by multiples of 60 degrees.
- Only certain cluster sizes and cell layout are possible.
- The number of cells per cluster, N , can only have values which satisfy
- Co-channel neighbors of a particular cell, ex, $i=3$ and $j=2$.

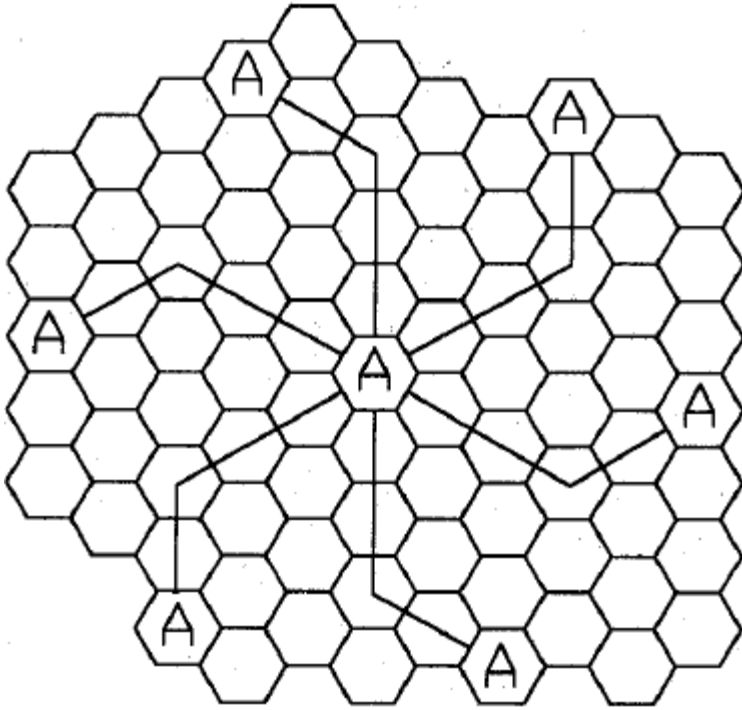

Cell Splitting

Unfortunately, economic considerations made the concept of creating full systems with many small areas impractical. To overcome this difficulty, system operators developed the idea of cell splitting. As a service area becomes full of users, this approach is used to split a single area into smaller ones. In this way, urban centers can be split into as many areas as necessary in order to provide acceptable service levels in heavy-traffic regions, while larger, less expensive cells can be used to cover remote rural regions. Handoff The final obstacle in the development of the cellular network involved the problem created when a mobile subscriber traveled from one cell to another during a call. As adjacent areas do not use the same radio channels, a call must either be dropped or transferred from one radio channel to another when a user crosses the line between adjacent cells. Because dropping the call is unacceptable, the process of handoff was created. Handoff occurs when the mobile telephone network automatically transfers a call from radio channel to radio channel as a mobile crosses adjacent cells. During a call, two parties are on one voice channel. When the mobile unit moves out of the coverage area of a given cell site, the reception becomes weak. At this point,

the cell site in use requests a handoff. The system switches the call to a stronger-frequency channel in a new site without interrupting the call or alerting the user. The call continues as long as the user is talking, and the user does not notice the handoff at all

- When a mobile moves into a different cell while a conversation is in progress, the MSC automatically transfers the call to a new channel belonging to the new base station.
- Handoff operation
 - identifying a new base station
 - re-allocating the voice and control channels with the new base station.
- Handoff Threshold
 - Minimum usable signal for acceptable voice quality (-90dBm to -100dBm)
 - Handoff margin cannot be too large or too small.
 - If is too large, unnecessary handoffs burden the MSC
 - If too small, there may be insufficient time to complete handoff before a call is lost.

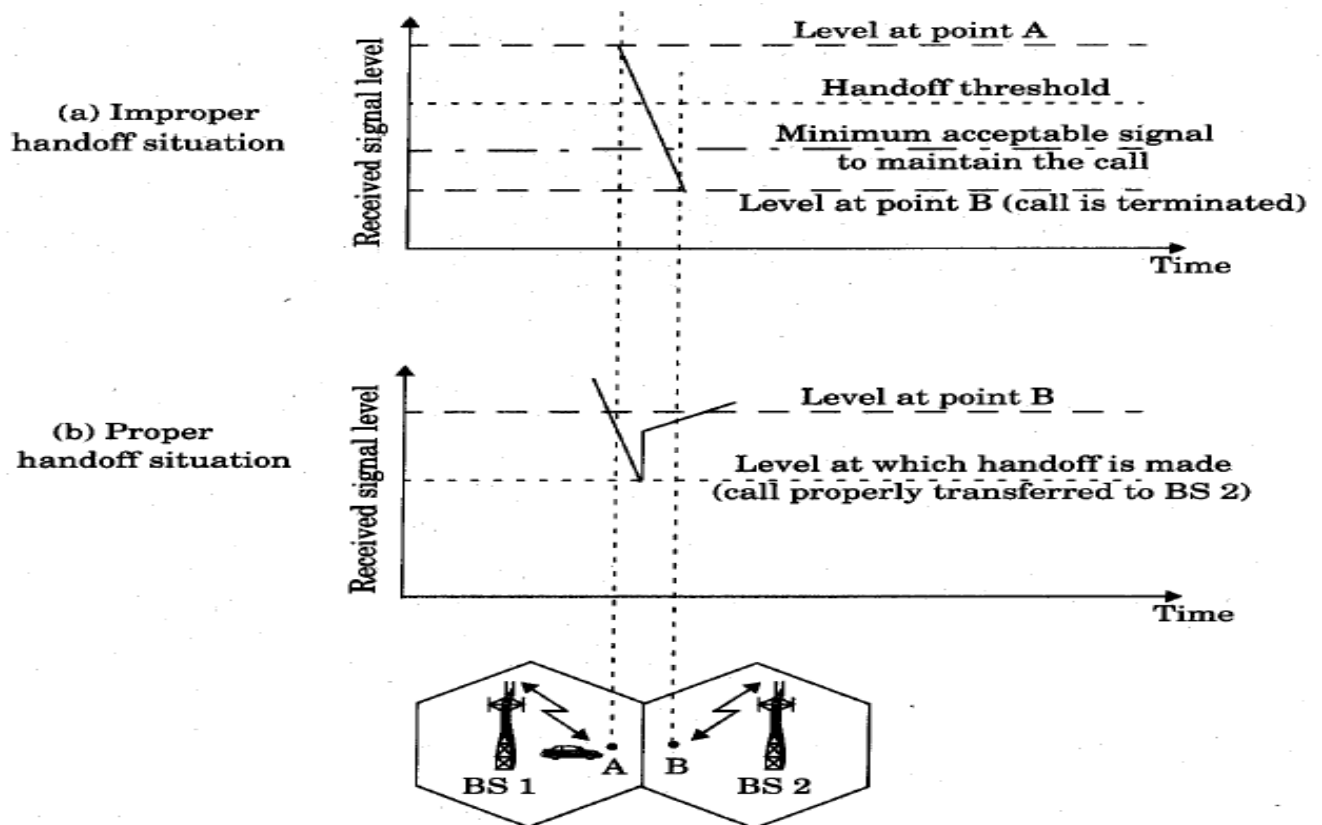

- Handoff must ensure that the drop in the measured signal is not due to momentary fading and that the mobile is actually moving away from the serving base station.
- Running average measurement of signal strength should be optimized so that unnecessary handoffs are avoided.
 - Depends on the speed at which the vehicle is moving.
 - Steep short term average -> the hand off should be made quickly
 - The speed can be estimated from the statistics of the received short-term fading signal at the base station
- Dwell time: the time over which a call may be maintained within a cell without handoff.
- Dwell time depends on
 - propagation
 - interference
 - distance
 - speed
- Handoff measurement
 - In first generation analog cellular systems, signal strength measurements are made by the base station and supervised by the MSC.
 - In second generation systems (TDMA), handoff decisions are mobile assisted, called mobile assisted handoff (MAHO)
- Intersystem handoff: If a mobile moves from one cellular system to a different cellular system controlled by a different MSC.
- Handoff requests is much important than handling a new call.

Block diagram of GSM

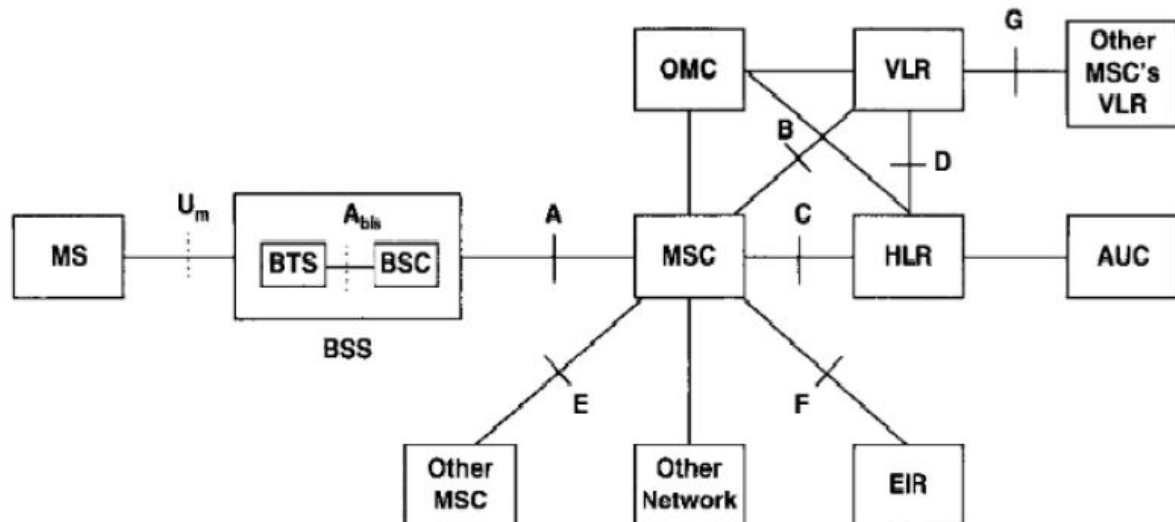

- **MS: Mobile Station**
- **BSS: Base Station Subsystem**
- **BTS: Base Transceiver Station**
- **BSC: Base Station Controller**
- **MSC: Mobile Service Switching Center**
- **OMC: Operations and Maintenance Center**
- **HLR: Home Location Register**
- **VLR: Visitor Location Register**

- GSM system layout is standardized
 - Standardization involves:
 - Elements of the network
 - Communication Interfaces
 - Standard layout allows for the use of equipment from different suppliers
 - Two functional parts
 - HW and SW specific for GSM radio interface
 - Subscriber Identity Module (SIM)
 - SIM – detaches user identity from the mobile
 - Stores user information
 - Without SIM – only emergency calls
- BSC plays a role of a small digital exchange.
- It can be connected to many BTSs and it offloads a great deal of processing from MSC
- One BSC connects to several tens to couple of hundred BTS
- Some of BSC responsibilities:
 - Handoff management
 - MAHO management
 - Power control
 - Clock distribution
 - Operation and maintenance
- TRAU is responsible for transcoding the user data from 16Kb/sec to standard ISDN rates of 64Kb/sec.
- It can physically reside on either BSC side or MSC side.
- If it resides on the MSC side, it provides substantial changes in the backhaul – 4 users over a single T-1/E-1 TDMA channel.
- TRAU, BSC and BTSs form Base Station Subsystem (BSS)

- Responsible for connecting the mobile to the landline side
- GSM MSC is commonly designed as a regular ISDN switch with some added functionality for mobility support
- GSM Network can have more than one MSC
- One of the MSC has an added functionality for communication with public network – Gateway MSC (GMSC)
- All calls from the “outside networks” are routed through GMSC

TDMA Access Scheme

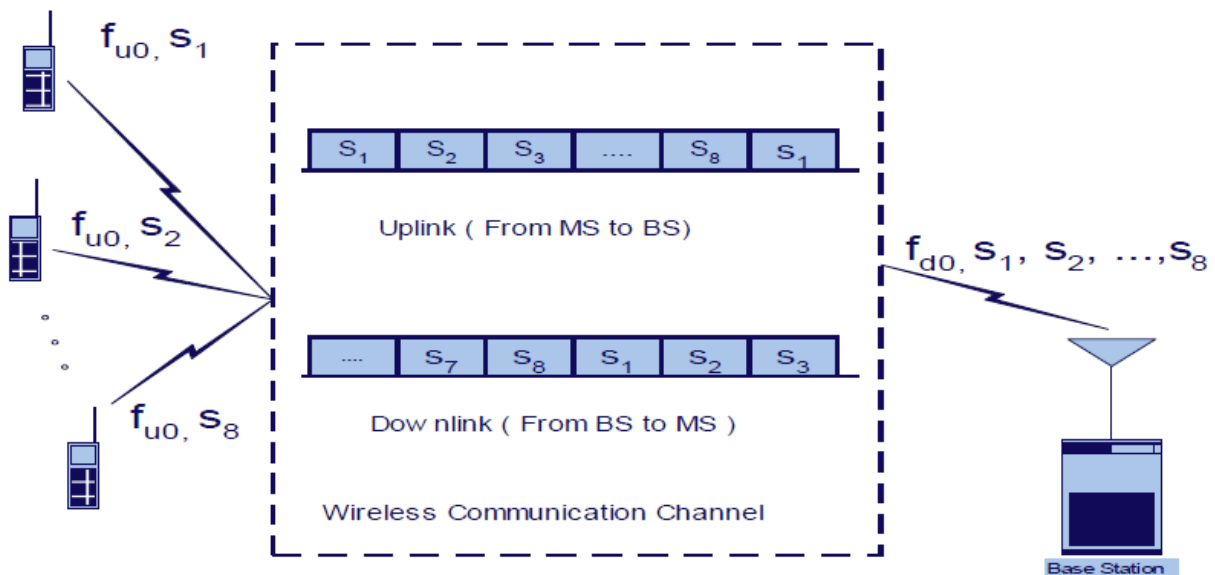

- Multiple users operate on the same frequency, but not at the same time.
- Advantages of TDMA:
 - Relatively low complexity
 - MAHO
 - Different user rates can be accommodated
 - Easier integration with the landline
- Disadvantages:
 - High sync overhead
 - Guard times
 - Heavily affected by the multipath propagation

